

Main engine starting air system

Arnaut, Alen

Undergraduate thesis / Završni rad

2018

Degree Grantor / Ustanova koja je dodijelila akademski / stručni stupanj: **University of Rijeka, Faculty of Maritime Studies, Rijeka / Sveučilište u Rijeci, Pomorski fakultet**

Permanent link / Trajna poveznica: <https://um.nsk.hr/um:nbn:hr:187:722383>

Rights / Prava: [In copyright](#)/[Zaštićeno autorskim pravom.](#)

Download date / Datum preuzimanja: **2024-09-12**



Sveučilište u Rijeci, Pomorski fakultet
University of Rijeka, Faculty of Maritime Studies

Repository / Repozitorij:

[Repository of the University of Rijeka, Faculty of Maritime Studies - FMSRI Repository](#)



uniri DIGITALNA
KNJIŽNICA



UNIVERSITY OF RIJEKA
FACULTY OF MARITIME STUDIES RIJEKA

ALEN ARNAUT

MAIN ENGINE STARTING AIR SYSTEM

FINAL PAPER

Rijeka, 2018

UNIVERSITY OF RIJEKA

FACULTY OF MARITIME STUDIES RIJEKA

SUSTAV ZRAKA ZA UPUĆIVANJE GLAVNOG MOTORA

MAIN ENGINE STARTING AIR SYSTEM

FINAL PAPER

Course: Engine room simulator

Mentor: Dean Bernečić, Associate Professor, PhD

Student: Alen Arnaut

Study direction: Marine engineering

JMBAG: 0112064589

Rijeka, june 2018

Student: Alen Arnaut

Study program: Marine engineering

JMBAG: 0112064589

STATEMENT

In which I state that final paper under title MAIN ENGINE STARTING AIR SYSTEM was made independently under the supervision of Dean Bernečić, PhD.

In this paper I used methodology of scientific research and the references listed at the end of the final paper. Other peoples knowledge, attitudes, conclusions, and principles cited or paraphrased in the final paper, were quoted and connected with footnotes, and bibliography units were used in common, standard way. The paper is written in standard English language.

I agree with the publication of the final paper on the official website of the Faculty.

Student

Alen Arnaut

SUMMARY

The starting air system described in this paper is used on engines with the fixed pitch propeller directly connected to the engine. Operations carried out by the system are: reversing, starting, sending speed signal and stopping of the engine. In order to achieve reversing operations in engine cycles must be retimed. This is done by reversing mechanism and starting air distributor retiming. When the direction of rotation is set, starting air is introduced into relevant cylinders and the engine starts to rotate. After it reaches appropriate speed, fuel is injected, and minimum speed is obtained. By sending signal to the governor engine speed is increased or decreased, depending on the command. When the needle valve on top of fuel pump is actuated engine is stopped. Regarding safety, systems is provided with several interlocks which prevent potentially dangerous events. In case of potential damage to the engine, slowdown and shutdown actions are carried out by the safety system.

Keywords: fixed pitch propeller, starting, stopping, reversing, retiming

SAŽETAK

Sustav zraka za upucivanje koji je opisan u ovome radu koristi se na glavnim motorima koji su direktno spojeni za brodski vijak koji ima neprekretna krila. Operacije koje se obavljaju tim sustavom jesu: prekretanje, upućivanje, povećavanje broja okretaja te zaustavljanje motora. Kako bi se postiglo prekretanje motora počeci operacija u ciklusu rada motora se moraju ponovno vremenski uskladiti. To se postiže pomoću prekretnog mehanizma te promjene položaja distributora zraka. Jednom kada je smjer okretanja motora zadan, uputni zrak ulazi u unaprijed određene cilindre te se motor počinje okretati. Nakon što je postigao dovoljnu brzinu, gorivo se uštrcava i minimalna brzina je postignuta. Slanjem signala do regulatora broja okretaja, broj okretaja motora se povećava ili smanjuje ovisno o naredbi. Kada se aktivira igličasti ventil na vrhu visokotlačne pumpe goriva, motor se zaustavlja. Zbog očuvanja sigurnosti, sistem je opremljen s više blokada čija je uloga spriječavanje potencijalno opasnih događaja. U slučaju potencijalne opasnosti za oštećenje motora, akcije usporavanja i zaustavljanja motora izvršavaju se pomoću sigurnosnog sustava.

Ključne riječi: brodski vijak s neprekretnim krilima, upućivanje, zaustavljanje, prekretanje, ponovno vremensko usklađivanje

CONTENT	I
1. INTRODUCTION	1
2. AIR AS CONTROL MEDIUM	2
2.1 Physical properties.....	2
2.2 Air humidity	2
3. MANOEUVRING AIR SYSTEM ELEMENTS	4
3.1 Air pressure reduction unit	4
3.2 Pneumatic valves	5
3.3 Starting air distributor.....	6
3.4 Starting air valve.....	8
3.5 Main/Automatic starting valve	9
3.6 Reversing mechanism.....	10
3.7 Safety systems and devices.....	11
3.8 Control room console	11
3.9 Variable injection timing servos.....	12
3.10 Starting air system auxiliary equipment	14
4. COMPRESSED AIR SYSTEM	14
5. MANOEUVRING AIR SYSTEM OPERATION	17
5.1 Remote control	17
5.1.1 Engine in the STOP position	17
5.1.2 Reversing	18
5.1.3 Starting	21
5.1.4 Controlling the speed	22
5.1.5 Stopping of the engine	23
5.2 Local control.....	23
5.2.1 Change-over with stopped engine	24
5.2.2 Change over with running engine	26
5.3 Crash stop manoeuver	26
6. CONCLUSION	28
REFERENCES	29
TABLE OF FIGURES	30

1. INTRODUCTION

The engines, as machines which use fuel as heat source to perform mechanical work over period, can be started in different ways, using different mediums and devices (power sources). Best example to show that is by observing diesel engine which is used to power emergency generator found on board today's merchant vessels. Since it is a crucial element in emergency situations, an engine powering this generator can be started electrically, hydraulically and pneumatically. Common to those systems is that the force required to start engine rotating is exerted on the engine flywheel, via device called starter. Torque is created and as the engine achieves required speed, atomised fuel starts to ignite and the engine is started. Those starting systems are good for some engines with lower power output, but when it comes to the large two stroke diesel engines used in propulsion on large merchant vessels, such way of starting an engine would be impractical. It would require enormous starting device, capable of moving heavy piston mechanisms. That is the reason why two stroke diesel engines used in a propulsion, are started by introducing pressurised air into the cylinders via starting air valves.

For purpose of better understanding of air starting system, simulator is used, where in detail all the elements and principle operation can be seen and shall be described. Simulator is created by Singapore Maritime Academy and is based on MAN K/L/S 50-70 MC series of engines. System consists of several key elements, which are connected in a network of pipes accompanied with many pneumatic valves. Engine can be controlled from Bridge, Engine Control Room or locally near engine side. Most of the control is done pneumatically. This points out to the question of physical values and properties air must possess in order to perform its function correctly. Sequence of actions from the moment signal is given from the bridge, till the engine is started shall be discussed. Unavoidable part of every system are its safety features which shall be highlighted during system presentation.

2. AIR AS CONTROL MEDIUM

In the air starting system air is used both as a medium for operating pneumatic valves (7 bar), control of other system's crucial elements and as force needed to initially start moving the engine(30bar). The only exception from previous statement are starting and pilot valves, which are operated by means of pressurised air of 30 bars. Advantages of air are numerous. Most important one is that there is abundance of air in the atmosphere so it's cheap to use, comparing to oil for example. Cost can only be seen as amount of mechanical work required to pressurise it. The air is not dangerous, so if any leakage is detected, air is vented to the atmosphere. It can be easily stored in air receivers, and kept there, always possessing potential energy to perform mechanical work.

2.1 Physical properties

Air is a mixture of gases in earth's atmosphere. Nitrogen has largest volume share (78,084%), oxygen (20,947%), argon (0,934%) and carbon dioxide (0,033%). It also contains water, not in the form of rain or mist, but in gaseous state. That is referred as air humidity, and it is not constant. Since it is mixture of two gases, total pressure of the mixture will be sum of partial pressure of each gas (dry air, water vapour). Some dirt particles are also contained in the air. After the rain, they are washed away, and thus visibility is increased. That is the proof of little particles floating in the air without being seen. At sea level pressure of air is 1013 kPa average. Again, depending on weather condition, it can deviate. Air is non-toxic and non-combustible but supports combustion.

2.2 Air humidity

Locally it depends upon other atmospheric conditions, but in general, there are climate areas on Earth where air humidity is much higher i.e. air contains more moisture and some areas where air is more dryer. If ship is sailing in tropical zone, Engine Room crew must drain air receivers and check air dryer unit more often, because air humidity, in that area is higher than average. Air humidity can be measured as absolute, relative and specific. Absolute humidity is amount of water in the air, expressed as mass per unit of volume. Relative humidity is expressed as percentage and measures the current absolute humidity, relative to the maximum i.e. when air becomes totally saturated with water vapour. Specific humidity is the ratio of the mass of the water vapour to the total mass of the moist air. When air reaches dew point it means that it is saturated with water vapour and relative humidity is 100%. From the following diagram we can see how temperature, moisture and enthalpy are related.

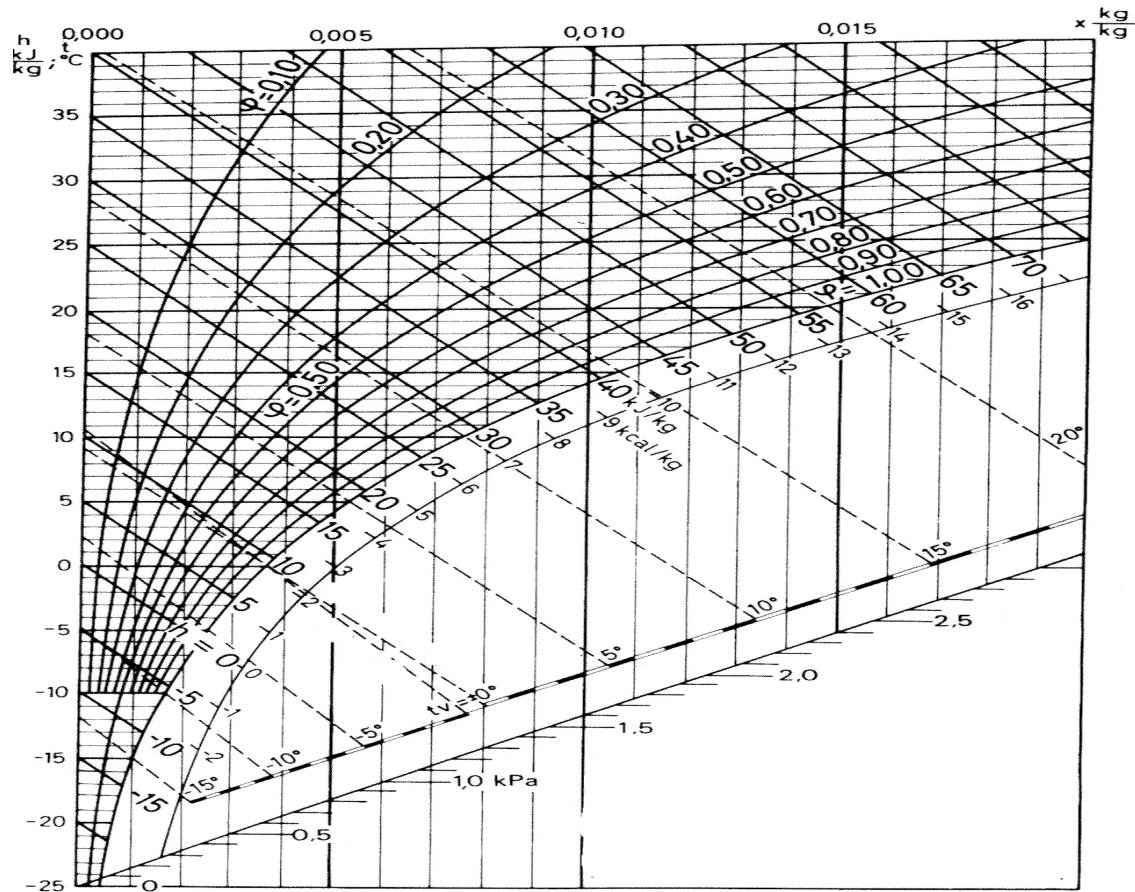

Figure 1 Mollier diagram

If the air receives heat, temperature and pressure values increase, specific humidity remains the same, but relative humidity decreases. This can also be expressed as property of air to contain more moisture on higher temperatures. In that case we are going away from air's dew point. By removing heat from the air, the temperature and pressure drop, relative humidity increases and when it reaches 100%, it reached the dew point and water vapour from the air will condensate. As long as the partial pressure of water vapour in air is lower than its saturation pressure for observed temperature, vapour won't condensate. Since the air is used as control medium in the engine starting system, special attention should be taken to the air quality. Air must be dry and clean of any dirt particles. Before it is used in operation, it passes through the dryer and filter. If the moisture in the air condensates, it can cause corrosion in pneumatic valves, air cylinders and so on i.e. risk of malfunction increases.

3. MANOEUVRING AIR SYSTEM ELEMENTS

As to understand starting air system properly, all its main parts and elements must be described. They are mostly mechanical parts where actions of opening and position changing is done by force of pressurised air (control/pilot air of 7 bar). Safety systems are also operated by means of 7 bar air supply. The springs are used to return moving parts of devices, back to the position of rest. Except for mechanical and pressure energy, electricity is used to actuate some pneumatic valves.

3.1 Air pressure reduction unit

After the air is properly treated and before it is introduced into starting air system for its control purposes, its pressure is decreased. Reason is simple, when small pressure is used, pipes, connections and valves are exposed to smaller force generated by pressurised air. Lesser construction firmness is required. Also, for control operation, pressure of 7 bar is more than enough, since all elements are easily operable. Essential parts of this kind of devices are the spring, the diaphragm and the needle valve, all enclosed within the housing. The pressure gauges are fitted on the inlet and the outlet. Spring exerts a force on a diaphragm which is connected to the needle valve. As the air enters through the needle valve into the main chamber, it pushes diaphragm, so the needle valve closes a bit. With decreased pressure air goes to the outlet of device, so the pressure in the chamber falls. Spring pushes diaphragm and the needle valve opens a bit, again allowing more air to enter. This actions constantly take place, as the systems tries to achieve force equilibrium. There are also other types, where in 2 steps pressure gets regulated, but the principle operation and main parts remain the same.

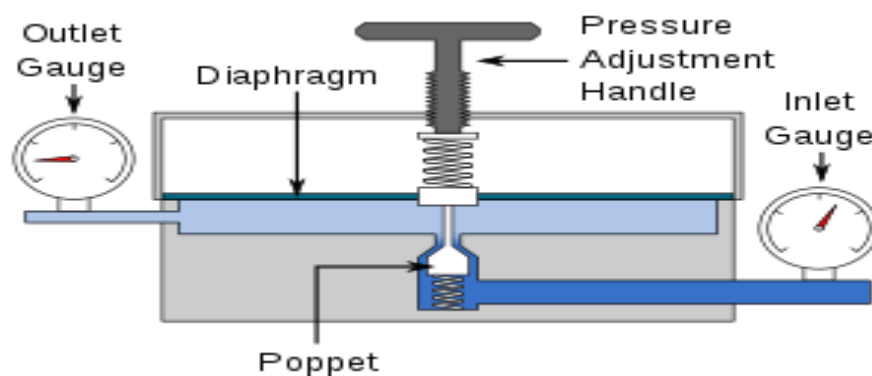

Figure 2 Air pressure reduction unit

3.2 Pneumatic valves

The main function of pneumatic valves in the starting air system is to control force and direct movement of control/pilot and safety air. Valves with this kind of purpose are often referred as directional control valves. They are distinguished by number of positions and number of pipes connected to them. In starting air system 2 position 3-way valves, 2 position 5-way valves and 3 position 5-way valves are used. Their position is changed by means of valve operator. That is a mechanism which has a purpose of shifting valve between its positions, thereby changing relations between connected pipes. Most commonly used are: levers, solenoid valves and air cylinders. Once the valve operators energy is removed (solenoid coil is de-energized or pilot air depressurised) springs return the valve into their rest position. Example of lever operated is the interlock C which is situated near turning gear. Depending on lever position, control air is supplied further or blocked. Secondly, remote control valves are operated from the engine control room or from the navigation brige. When signal is sent, electricity passes through the coil (solenoid) thus moving spool from its position thereby allowing fluid to pass, in this example control air. In the case of air pilot operating valve, plunger is moved by force of pilot air. The following picture shows the construction of pneumatic valve operated by solenoid valve.

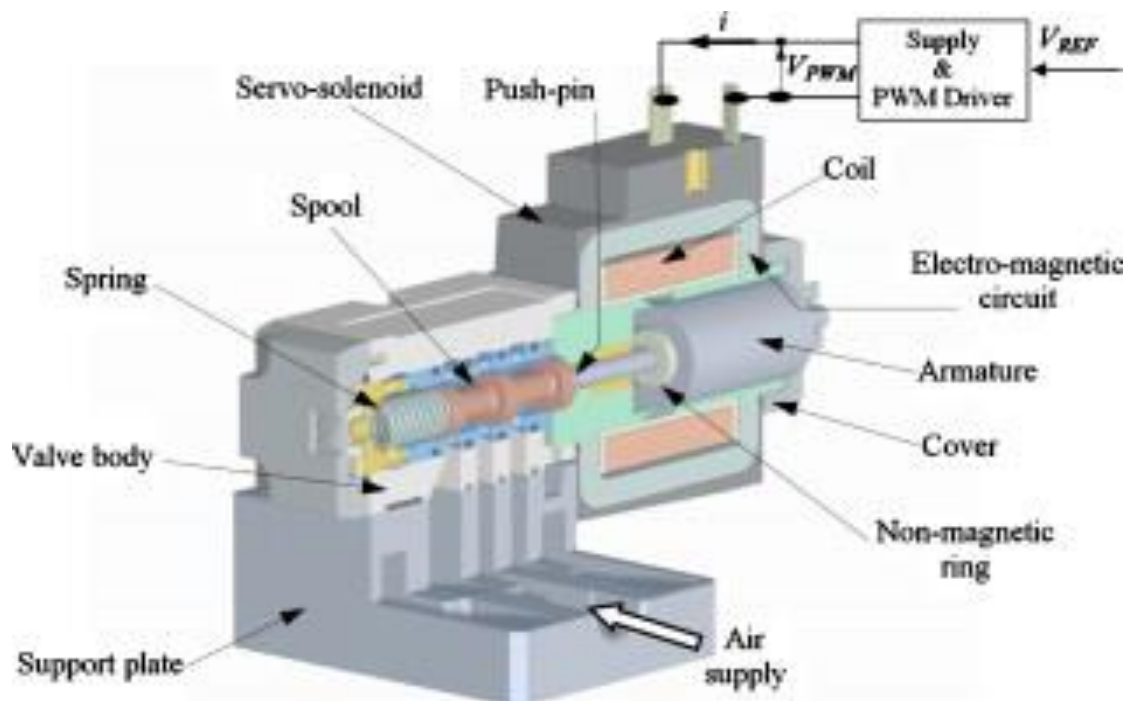

Figure 3 Pneumatic valve operated via solenoid

3.3 Starting air distributor

There are 2 main types of starting air distributor. Their main difference is in the positioning of pilot valves which can be positioned circumferentially or in line, so we distinguish radial and line types. For the purpose of this paper, radial type shall be described. Function of starting air distributor is to distribute the pilot air to the main starting valves in appropriate order. It consists of a housing which has radial bores depending on the number of engine cylinders, and one axial bore for camshaft. It should be noted that engines can have a big number of cylinders (10, 12). In that case, 2 distributors can be fitted, each on every end of camshaft. The camshaft is used to operate pilot valves, which slide in the liners fitted in radial bores. Cams with peaks or cut-outs can be used, depending on the design. Pilot valves are pushed onto cams by means of some springs. Because of the shape cam has, one or two pilot valves (depending on number of cylinders) will always be open therefore allowing pilot air to reach main starting valves. Firing order of the engine, is achieved by the sequence at which pilot valves are opened by starting air distributor. For example: if the engine has 6 cylinders, the firing order is 1-5-2-6-3-4 and the clockwise engine rotation is for ahead direction. Then if we imagine a circle, at 12 o'clock will be positioned pilot valve for cylinder number 1. 60 degrees in clockwise direction pilot valve for cylinder number 5. 60 degrees more, i.e 120 degrees from 12 o'clock position pilot valve for cylinder 2 is located, and so on. Regarding MAN B&W engines on which this simulator is based, reversing of air distributor is achieved by means of air cylinder. Also, air used to operate starting air valves (pilot air) has a value of 30 bar and comes from the main starting valve pipeline.



Figure 4 Starting air distributor

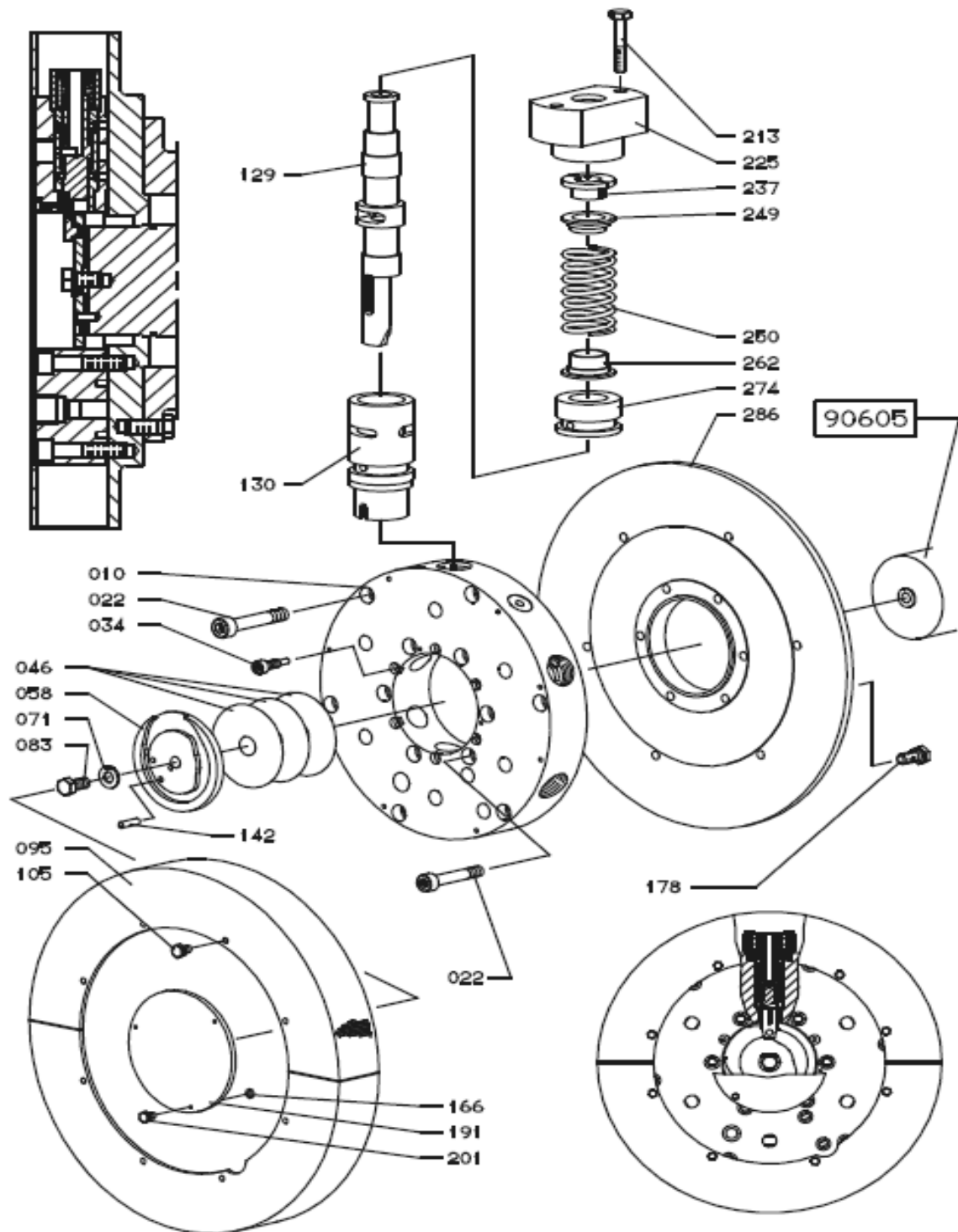

Figure 5 Starting air distributor

Numbers from the last picture are matched with distributor elements:

010–housing; 022–screw ; 034–guide screw ; 046–disc ; 058 –starting cam ; 071–lock washer ; 083–screw ; 095–cover ; 10 –screw ; 129–piston valve slide ; 130–liner ; 142–guide

pin ; 166-washer ; 178-screw ; 191-cover ;201-screw ; 213-screw ; 225-union nut 237-locking ring ; 249-spring guide ; 274-liner ; 286-cover

3.4 Starting air valve

Starting air valve is a mechanical device used to introduce starting air (30 bar) into the cylinder/s of the engine. It is located in the cylinder head.

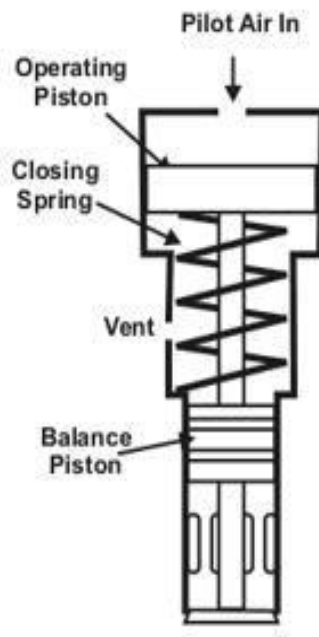

Figure 6 Starting air valve

Construction of the valve is simple. Forces that operate the valve are based on:the value of air pressure acting on the surfaces and the force generated by the spring i.e. spring characteristics. From the main starting air line, air of 30 bars pressure enters the lower part of the valve. Pressure force is distributed evenly on all surfaces, but since the surfaces are all the same size, valve remains pneumatically balanced, and does not open. Only force which holds the valve shut is the spring force. On top of the valve, a pipe is located which connects starting air distributor and the starting valve. When the pilot valve from the starting air distributor enters in the upper part of the valve, pressure of pilot air acts on the operating piston thereby overcoming the spring force and opening the valve. Valve is kept open until the pilot valve operating that valve becomes closed and then spring returns it into closed position.

3.5 Main/Automatic starting valve

The main starting valve also named the air master valve or automatic valve is a device which allows or blocks main starting air (30 bar) to the starting air valves. Basically, it is a simple ball valve which can be turned for maximally 90 degrees. This valve is operated pneumatically e.i. has pneumatic cylinder where opening and closing of the valve is done by means of a axial movement of the piston. Master valve has a wheel which is used to locally shut down valve. Local shut down is important part of the procedure if any part of the start air system requires maintenance work. Beside main starting valve, slow turning valve is fitted. Its function is to allow starting air into the cylinders, but for different purpose. Air is used to blow the engine with air, so to check if any jacket cooling water has leaked into the cylinder. Another function is turn the engine, so all the moving parts of the piston mechanism can be lubricated properly. Slow turning device is not installed on all ships and power plants but is very useful for safe operation. Many accidents which caused a lot of damage on main engines have occurred. Reason was presence of liquid in the cylinders, which could have been detected earlier if the slow turning device was installed and used.

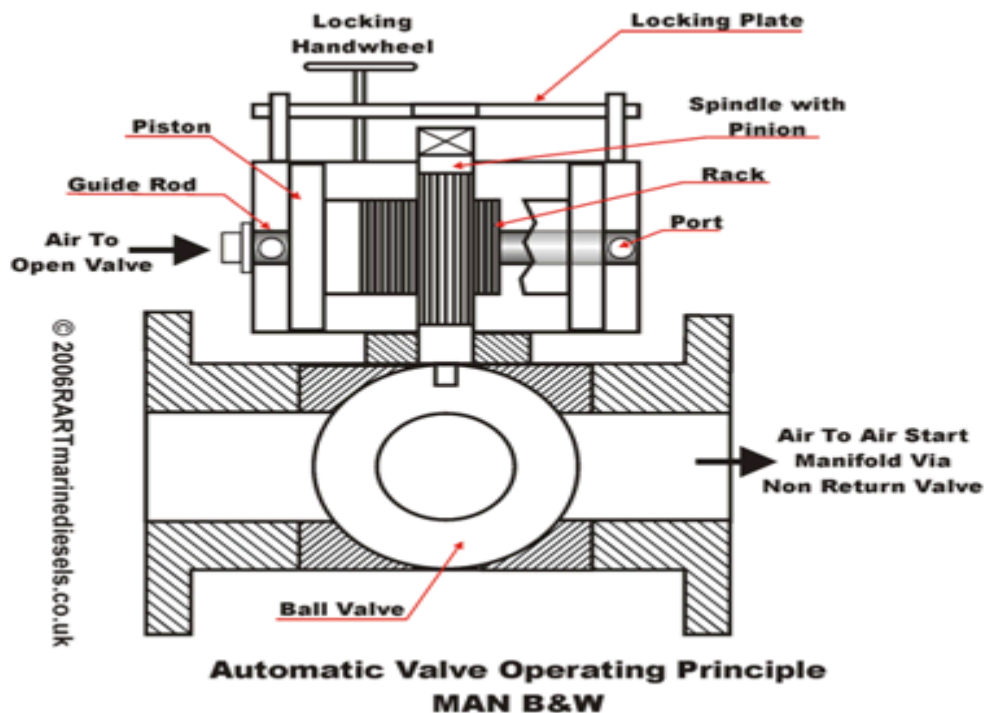

Figure 7 Main/automatic starting valve

3.6 Reversing mechanism

Function of this mechanism is to achieve retiming of the fuel pump i.e. to change the moment of fuel injection. Reversing as it completely is, shall be described later in the paper. For now, focus will be only on device itself. 2-stroke diesel engine manufacturers have different ways of achieving the same thing. MAN-B&W K/L/S 50-70 MC engines have fuel pump cams fixed directly to the camshaft. When running in the astern direction, engine will rotate anticlockwise, so it will be the opposite flank of the cam which will rise the pump plunger to deliver fuel. If the follower roller remains in the same position, fuel injection will start 2 degrees after the top dead center, resulting a low efficiency engine operation. By means of pneumatic cylinder, piston and the link, and power of control air (7 bar), follower will be displaced so the timing of the fuel pump is altered. Mechanism is self-locking in either positions and sensors (magnet switches) indicate if the follower is locked in the correct position. If not, fuel will be cut-off from the fuel pump, and indication of reversing failure will be visible on navigation bridge and engine control room.

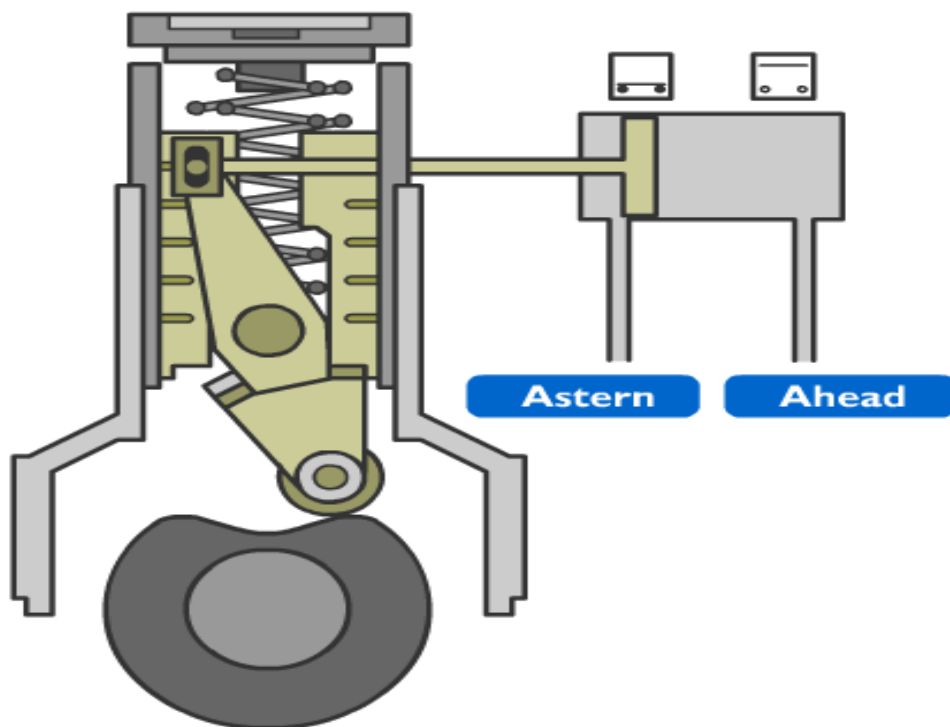

Figure 8 Reversing mechanism

3.7 Safety systems and devices

The starting air system operates in the appropriate sequence of actions. If that sequence would become distorted, system could easily damage itself, and the engine can become severely damaged. For the system protection purpose interlocks and safety system are installed. Interlock A prevents starting air being admitted till engine timing has been adjusted. This prevents starting of the engine in the wrong direction. Interlock B blocks the starting air by deactivating air distributor when fuel is being injected. If the interlock did not perform its function, possible situation could be admitting starting air at the same time as the fuel is being injected. Explosion hazard would be inevitable. Interlock C is activated if the turning gear is engaged. It is one of the safety measures when performing maintenance work on starting air system. An independent safety system is provided to slow down and shut down the engine if there is serious malfunction. If a fault develops and the appropriate measures are not taken by crew in the engine room within stipulated time, engine slowdown is activated. The signal is sent to the governor which reduces fuel pump index, thereby slowing the engine. Common faults in this category would be: high - lubricating oil, colling water and exhaust gases temperature, low lubricating oil pressure, high oil mist etc. If the situation does not improve after further interval, engine shutdown is activated. Safety pilot air is led to the puncture valve on each fuel pump thus terminating fuel injection and stopping the engine. Engine shutdown can also be directly activated if the faults like overspeed, and low low main lubricating oil pressure occur. In the case of emergency, engine can be started and maneuvered locally from engine side control console.

3.8 Control room console

It is a console located in the Engine Control Room and it is used to control engine remotely. It is equipped with multiple switches, maneuvering handle and telegraph. Switch number 78 – is used to activate slow turning valve 28 during control-room control. Switch 79 – is activated when engine fails to start. Fuel limit to governor is canceled thereby chance of successful starting of engine is increased. Switch 80 – is used to change between bridge control and control-room control. Switch 176 – provides ahead signal to the remotely controlled valve 86 when control handle is in ahead position. Switch 177 – has a same function as the previous one but for astern direction. Switch 61 – function of this switch is to reset shutdown function (in safety panel) when regulating handle is in stop position. Potentiometer 62 – its function is to regulate speed setting signal to the governor during control-room control. Switch 63 – provides stop signal to the remotely controlled valve 84

and is actuated when the control handle is in STOP, START and position in between those two. Switch 64 – is actuated when the control handle is in START position and provides start signal to valve 90.

3.9 Variable injection timing servos

Although control air is used in operation of maneuvering system and for closing exhaust valve, it is also used to operate variable injection timing mechanism of fuel pumps. Fuel pump for series of engines on which this simulator is based are equipped with VIT (Variable injection timing). With this upgrade, pumps have capability to increase maximum combustion pressure in the engine cylinder, during loads at which otherwise, wouldn't be possible. By doing so specific fuel consumption can be decreased. Variable injection timing mechanism operates between 40 and 85 % of MCR (Maximum continuous rating). Mechanism is mechanical-pneumatic type and consists of a following elements.

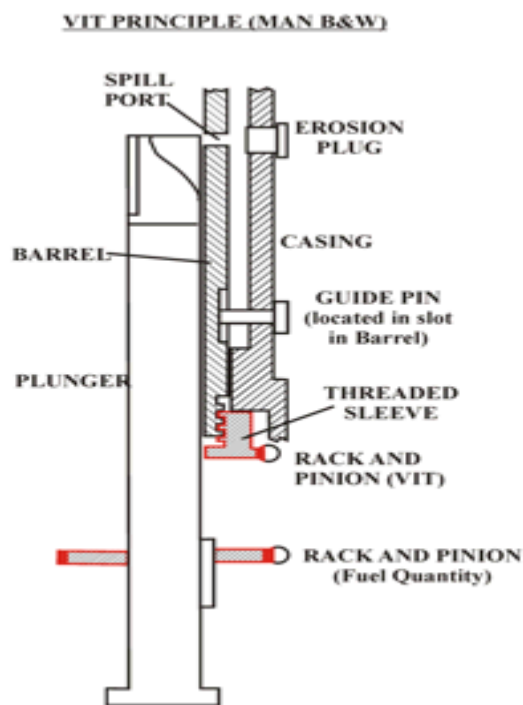

Figure 9 Fuel pump with VIT system

Fuel pump has a barrel with threaded bottom, located in the threaded sleeve. When the sleeve rotates barrel goes up or down (depending on the direction of sleeve rotation). Consequentially plunger will cover spill ports before if the barrel moves downwards, and later, if barrel moves upwards. Therefore, we can conclude that the start of injection can be

advanced or retarded depending on the position of a spill ports, relative to the fuel plunger. Threaded sleeve is connected via rack to the air cylinder. Control air is introduced by means of a VIT activator, marked with number 52 in starting air system. It is basically 3 position 5-way pneumatic valve. Control air is directly supplied to a VIT activator, which is in closed position until pilot air coming from pressure regulating air actuates it. Pressure regulating valve marked with number 53 is the key element in control of VIT. Pressure of pilot air to the VIT Activator determines position of a piston in air cylinder, which via rack places threaded barrel with its spill ports in required position. Pressure regulating valve is connected to the governor or fuel pump control handwheel via link. Simultaneously as the fuel index changes, so does the position of link (pivoted bar) thereby increasing or decreasing pilot air pressure which operates VIT activator. Other elements in the system are throttle non-return valve 49 which controls the time delay of the pilot signal to the VIT activator during AHEAD running. Valve 40 blocks pilot signal to the VIT activator during STOP or running ASTERN because variable injection timing doesn't operate within those conditions. When engine is stopped or runs astern, reducing valve 59 has a function to control the pre-set pilot pressure to VIT activator.

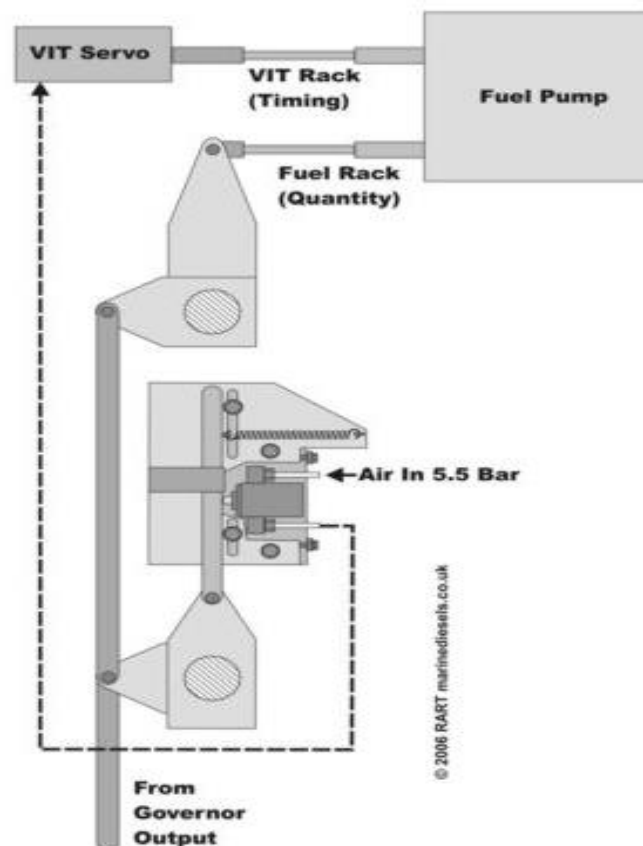

Figure 10 VIT mechanical-pneumatic mechanism

3.10 Starting air system auxiliary equipment

Air receivers of 40 litres (maneuvering system) and 20 litres (safety system) are fitted in the system to reduce lags in operation. Ball valves are fitted on the bottom of air receivers for draining. Valves for manual cutting-off of control air are installed in several positions in the pipeline. They are used to isolate part of the system if the maintenance work is required. Pressure switches and sensors detect if the air pressure is too low and activate the alarm. System is automatically blocked and prevents further operation. Pressure gauges are used to indicate air pressure. Double non-return valves are used since pipes from local and remote control intersect.

4. COMPRESSED AIR SYSTEM

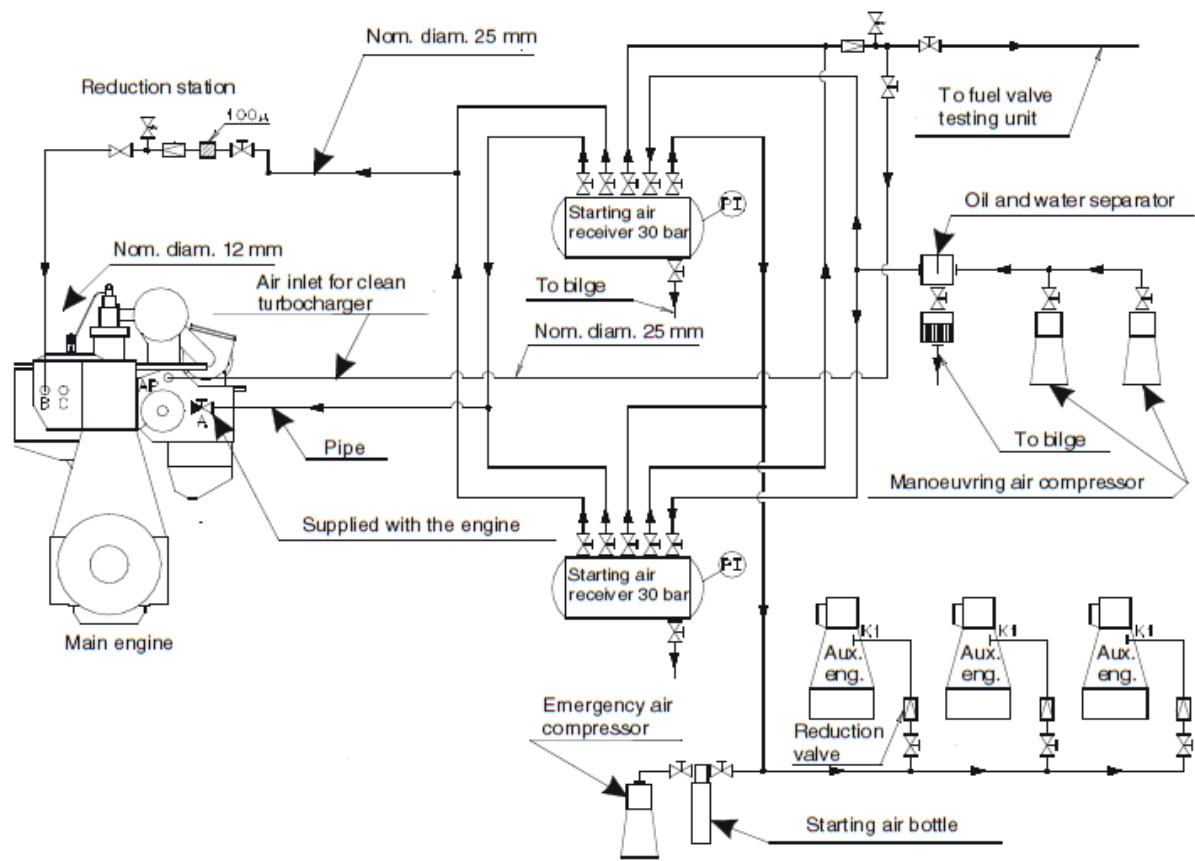

Figure 11 Starting air system

So far, in this paper were described elements of the maneuvering system for main engine, from reduction units to the starting air valves. Figure above shows compressed air pipeline and elements whose function is to supply main engine with compressed air. Air is sucked from the engine room atmosphere by the compressor. In case of 2 stage piston compressor air is pressurised in first stage, then cooled and pressurised in the second stage, reaching 30 bars and again being cooled in second stage cooler. Before it is stored in starting air receivers, compressed air passes through oil and water separator. There it is rid from particles of both mediums (water and oil) and fills the receiver. Oil and water separator drains automatically into the bilge. There are 2 main compressors and one emergency compressor. Usually one of those two is set to be „master”. That one will always start first, when the pressure in the air receivers falls below set value. It is recommended to switch master command from one to the other in longer period of time, so they are equally used. By means of high pressure switch (HPS) compressor is stopped, because air in the receivers has reached 30 bars. Similar compressor will be started by means of low pressure switch (LPS) when pressure in the air receivers drops below certain value. System is cross-connected which means that one compressor can fill both receivers. Emergency compressor is used in emergency situations. It draws electrical power from emergency switchboard. Usually there is a third compressor with similar technical characteristics used to pressurise air which is later used as service air. While managing compressors operation in normal ship exploitation (for example during navigation), it is useful to use only one of those 3. It is possible because starting air receiver and service air receiver are connected via pipe, so air can flow from starting air receiver to service air receiver. Service air compressor is left in local control with valves in closed position. By doing so we are using only one compressor for whole ship air consumption. Since 2 of them are always in position of rest, wear of their moving parts is 0 and they are always ready for use. Consequence of this managing are savings in spare parts cost, and less maintenance work around compressors. Capacity of compressors is defined by classification society which states that compressor must be able to fill air receiver in one hour from atmospheric pressure to the 30 bars. Also, capacity of air receiver must be such to allow for 12 engine starts in case of directly coupled engine with fixed pitch propeller, which is the case with series of engines on which this simulator is based. Usual practise in engine room is to keep one receiver as a reserve, isolating it by closing inlet and outlet valves. Second one is used to supply air to the compressed air system and is topped up from main compressor which is set as master. Receivers are equipped with drain valves at their bottom, pressure gauges for pressure indication and safety valves. Safety valves open when pressure

in the receiver rises above nominal value i.e. 30 bars for 3-5 %. From the receivers, main and auxiliary engines are supplied with pressurised air. Difference is that auxiliary engines use air which has reduced pressure to value to 7 bars. Device for starting auxiliary engines is located near flywheel and it is basically turbine driven by compressed air.

The following figure shows compressor air system on the vessel Al Rakeyyat.

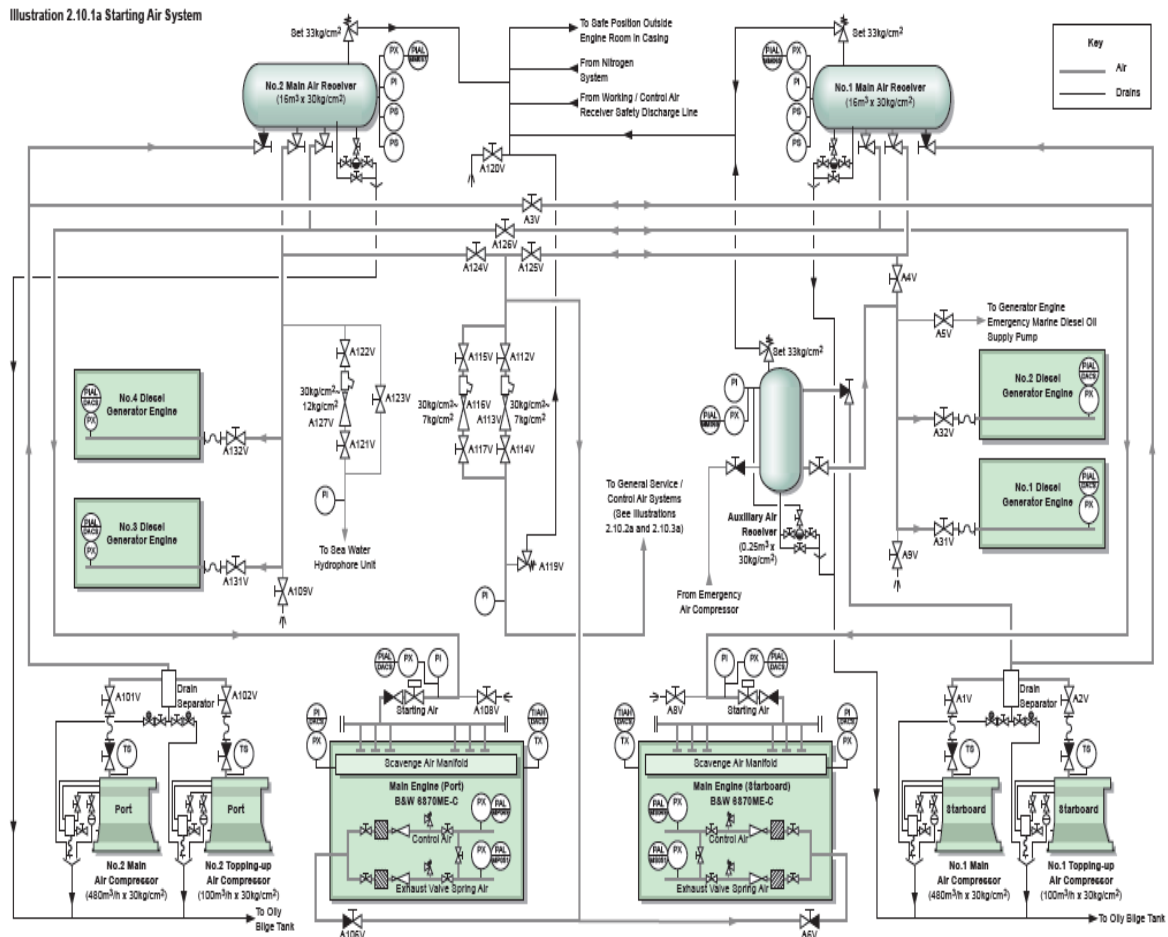

Figure 12 Compressed air system vessel Al Rakeyyat

This type of engine room is not common. For obtaining much greater redundancy of the machinery space, this vessel has 2 engine rooms separated by longitudinal bulkhead. Even in the case of serious events such as engine room flooding, this vessel can safely reach first port using only one of two main engines i.e. port or starboard machinery space. Crossover valves and pipeline allow for port and starboard sub-systems to be interconnected.

5. MANOEUVRING AIR SYSTEM OPERATION

Simulator is made in the schematic diagram style. Operations of reversing, starting, controlling of the speed and stopping can be simulated, therefore a student can understand principle operation of the system, in a more detailed way. System can be operated remotely or locally from engine side console. All pneumatic valves and other elements are marked with the number. On the following scheme we can see state of the system when the engine is stopped.

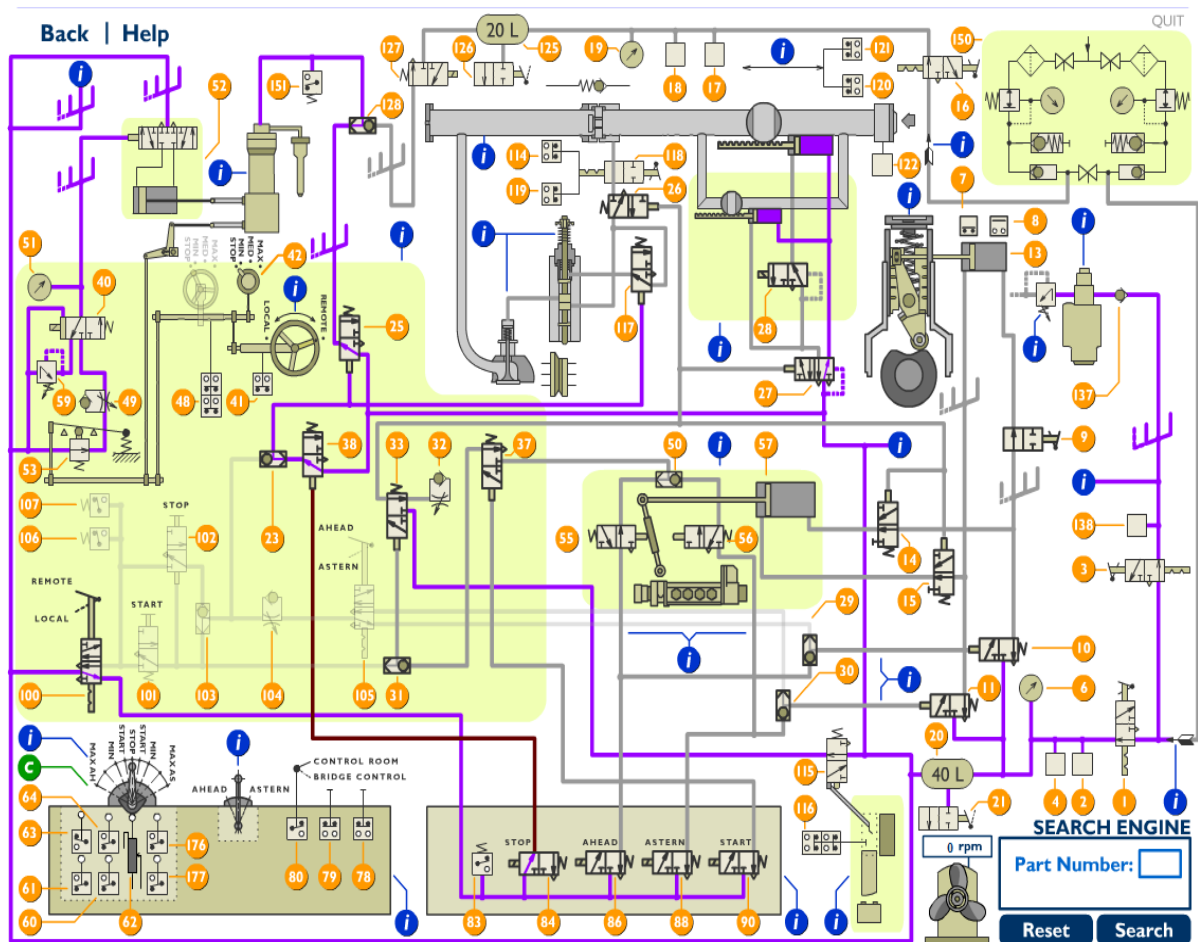

Figure 13 System when engine is stopped

5.1 Remote control

5.1.1 Engine in the STOP position

From the reduction unit 2 pipes are led to the system. Via first pipe, safety pilot air is led to the valve no. 127. When shut down signal is given, valve no. 127 opens, and air signal actuates puncture valve on the fuel pump. Second pipe leads control air to many other pneumatic valves, including the exhaust valve. Control air for the exhaust valve has a same

function as the normal mechanical spring i.e. closes the exhaust valve when oil pressure drops. Control air reaches valves no. 10 and no. 11. They are in closed position. Their function is to operate air cylinders of fuel pumps and air distributor depending on the desired direction of engine rotation. After the receiver pipeline branches in several directions.

Direction number 1- this line goes to the valve number 100, and VIT servos. Valve no. 100 is important valve because local or remote control of the system is determined via its position. System is operated remotely, so the control air is led to the remote-control valves. No. 84 is opened when stop signal is given, no. 86 for ahead direction, no. 88 for astern direction and no. 90 for start signal.

Direction number 2- control air is also led to the valve no. 115 also named Interlock C and is operated via lever. When turning gear is engaged, lever closes valve, and engine starting is blocked. In this scenario, turning gear is disengaged and the spring keeps valve in open position, allowing control air to reach valve no. 33. It is in the closed position.

Direction number 3- control air goes to the valve 27, 25 and 38. Construction of the valve no. 27 is such that control air which is led to it opens valve and goes further through the pipeline. In this case, air is led into cylinders which operate main starting valve and slow turning valve. Since engine is in the stopped position, main starting valve and slow turning valve are closed.

Remote control valve for stopping is opened so the stop signal is led to the valve 38. It moves valve into open position and the control air reaches valve no. 25 and no. 117. Again, by means of pneumatic operation, valve is opened, and control air is led to the fuel pump puncture valve, which is then opened. Now the pressure and the suction side of the fuel pump are connected, and fuel injection is not possible. Because air actuated valve no. 117, pilot valve on air distributor can be opened if the engine desired direction of rotation is set. Engine is stopped.

5.1.2 Reversing

During maneuvers engine is often stopped, reversed and then started again. The question arises about how engine is made to rotate in different direction, and what are the requirements for such operation. In two stroke diesel engine, there are 5 key points or moments in one complete engine cycle. These are: starting of fuel injection, opening of exhaust valve, opening of scavenge ports, closing of scavenge ports and closing of exhaust

valve. We can add opening and closing of starting air valve which operates only when engine is started. We will now consider connection between moments in operation with direction of rotation.

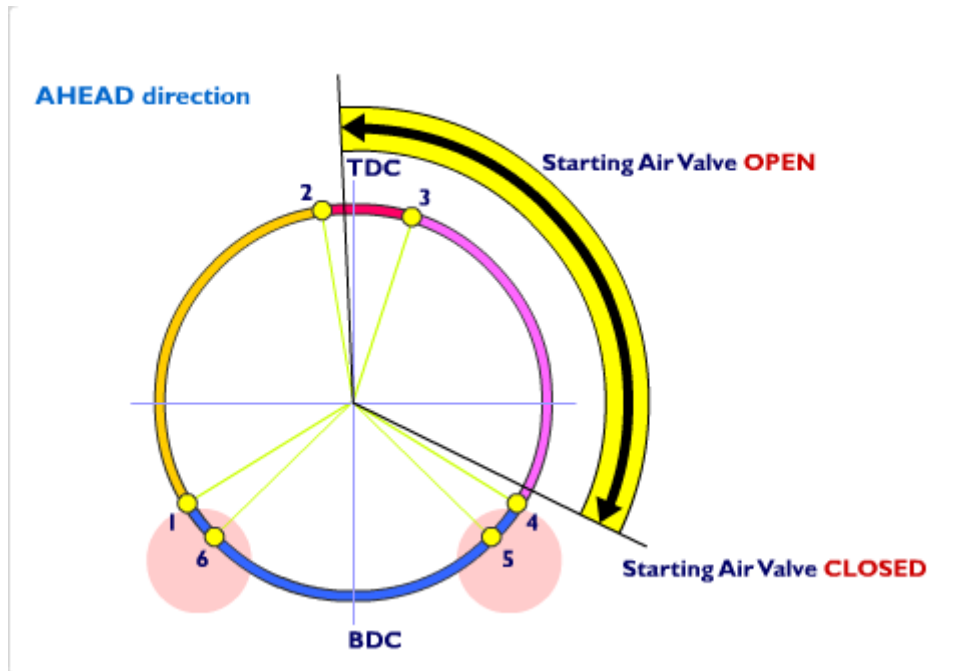

Figure 14 Distribution diagram # 1

1 – Exhaust valve closes; 2 –Fuel injection starts; 3 – Fuel injection stops

4 – Exhaust valve opens; 5 – Scavange ports open; 6 – Scavange ports close

From the figure 10. it can be seen that the position of numbers 4 and 5 are symmetrical to the 1 and 6. That means that whatever rotation engine has, exhaust valve and scavange ports will open and close at exactly same moments. This statement is valid only for the engines where camshaft operates exhaust valves. But it must be mentioned that today's modern engines have electrically controlled exhaust valves, so camshaft is unnecessary. This type of engines can change moments of opening and closing relative to the crank angle. Retiming of exhaust valves and scavange ports won't be necessary since exhaust valve for series of engines on which this simulator is based is operated by means of camshaft. Now let's assume that the engine has started the rotation in opposite direction e.i. astern direction. The points on the diagram remain in the same positions. Nothing wrong about 1, 4, 6 and 5. But number 2 is now on the wrong side, which means that the starting of injection happens

2 degrees after the top dead centre. Since the process of power stroke does not happen instantaneously, combustion takes place further into the cycle resulting in high exhaust temperatures and lower engine efficiency. For that reason, reversing mechanism is fitted on the fuel pumps, which then retimes the moment of fuel injection, placing it back 2 degrees before top dead centre. But even if the retiming of the fuel pump is achieved, that does not mean that the starting of the engine, in desired rotation is possible. When engine starts in ahead direction, air enters into different cylinders in different sequence then when it starts in astern direction. If we look at the distribution diagram and numerate the degrees in the clockwise direction which is direction for ahead running, the top dead centre will be 0 and degree before it will be 359. The air starting valve is opened for approximately 110-120 degrees. Consequence of the retiming of a starting air distributor will be that the system is now set to release starting air into the cylinders which are found between 240 and 360 degrees. If the engine has 6 cylinders, there will always be 2 of them. By doing so engine starts to rotate in the opposite direction, and the cycle runs smoothly because fuel pump injection has been retimed.

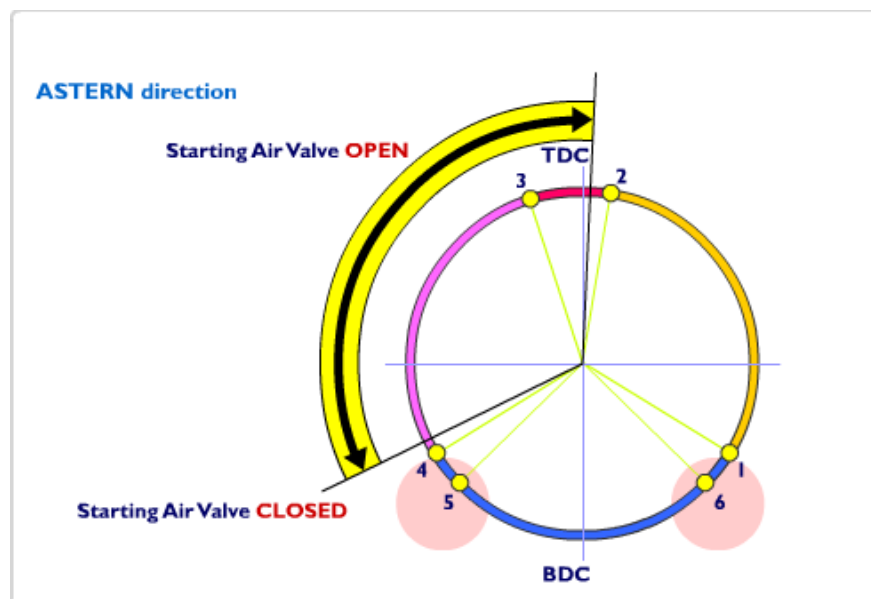

Figure 15 Distribution diagram # 2

Operation of reversing in the simulator goes as follows. Remote valve 88 for astern direction opens and the air is led into two directions. Via first pipe it comes to the reversing Interlock A (valve no. 56 – Astern direction). Since engine is not reversed i.e. retimed, it blocks the air. Via second pipe air is led to the valve no. 11 which distributes air to the reversing cylinders: number 13 (fuel pump) and through valve no. 15 to no. 57 (air

distributor). When piston in the air distributor reversing cylinder reaches dead position, lever actuates interlock A and the air is led to the valve no. 37 which is in closed position. Reversing is finished, and engine is ready to be started.

5.1.3 Starting

When the signal from the place of control (Navigation Bridge or Engine Control Room) is sent to the valve no. 90, it opens, allowing control air to actuate valve no. 37. Valve opens allowing control air coming from reversing pipeline to actuate valve no. 33. Valve opens allowing starting air to actuate valves no. 26, no. 27, no. 14 and no. 15. Valves no. 14 and no. 15 are now in closed position, thus preventing reversing of the engine, during process of starting. Valve no. 27 is switched into second position and now leads control air directly and via valve no. 28 into the air cylinders of slow turning valve and main starting valve thereby opening them. By opening main starting valve air of 30 bars pressure is led to all starting valves. But due to pneumatic balance and spring force they remain closed. Each of the pilot valves are operated by means of air drawn from main starting pipeline (30 bar). Because the valve no. 26 has been opened by control air, starting air now actuates pilot valve which operates adequate starting valve. By opening starting valves, air is introduced into the cylinders and engine starts to rotate.

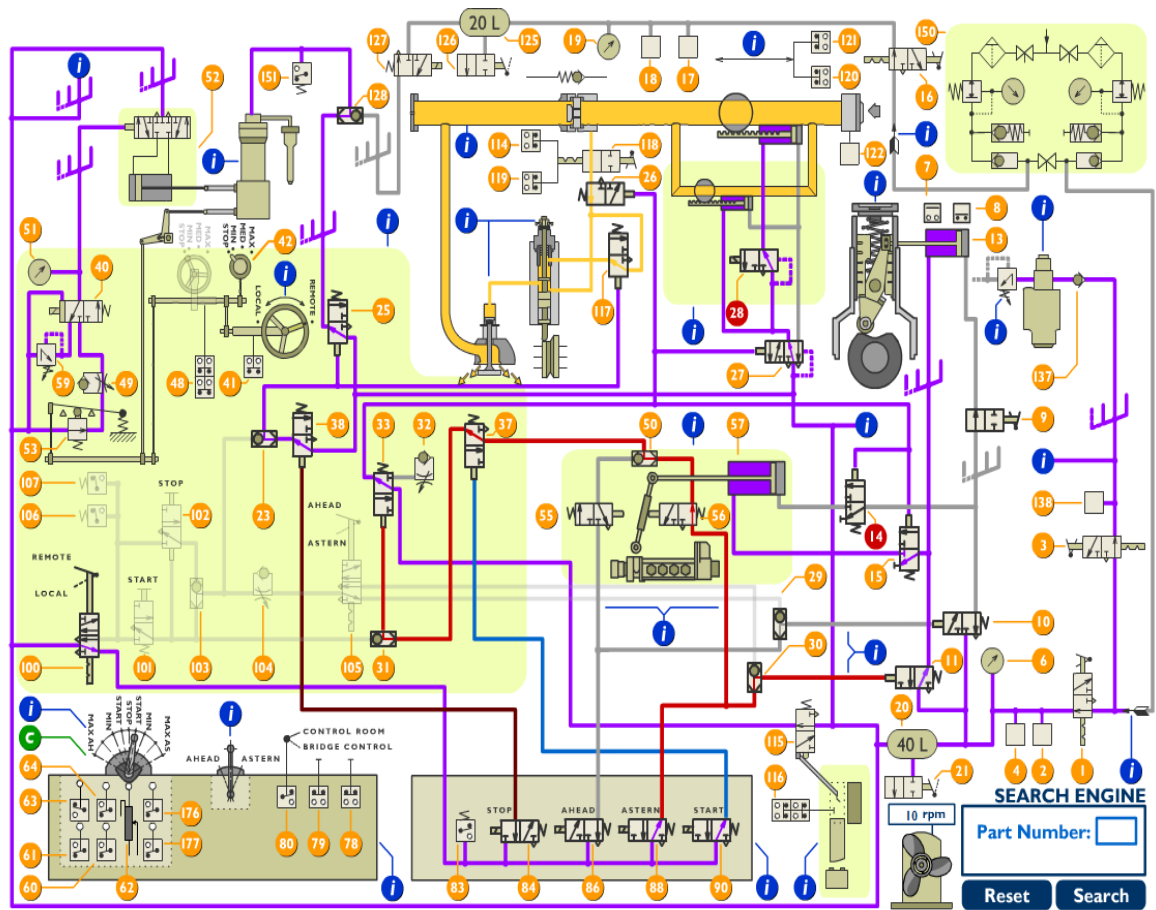

Figure 16 Reversing and starting

5.1.4 Controlling the speed

Initial start of the engine by means of pressurised air is only required until sufficient speed is obtained, so the fuel combustion starts to take place. Valve number 32 is throttle non-return valve which has a purpose of delaying venting of a pilot air to valve 26 and 27. By doing so, those valves change their position. Valve no. 26 changes to closed position, thereby blocking pressurised air (30 bar) to the pilot valve on air distributor. Although camshaft operates pilot valves on air distributor, there is no air, so actuation of starting valves is not possible. More though, valve no. 27 now leads control air to the other side of air cylinders of main starting valve and slow-turning valve, thereby closing them. Starting of the engine by means of air has finished. Through governor link engines speed can be increased. Pneumatic valves no. 25, no.38, no.33, no.37, no.26, no.117, no. 28 are now in closed position.

5.1.4 Stopping of the engine

Solenoid valve no. 84 for stopping of the engine is opened and pilot signal reaches puncture valve on the fuel pump and interlock B i.e. valve no. 117 via valves no. 38 and no. 25. Valve no. 117 is now in the open position, ready to allow control air to the pilot valve when engine is to be started.

5.2 Local control

Engine is most of the time operated remotely from navigation bridge or engine control room. But in the events of breakdown of remote control pneumatic maneuvering, the governor or its electronics, engine can be operated from local console located by the side of the engine. Drills must also be performed, where scenario of emergency control are simulated. Engine local control console is equipped with: several manually operated pneumatic valves, remote/local change-over mechanism consisting of impact wheel and speed regulating wheel e.i. fuel regulating wheel and switches. Change-over to local control can happen in two different situations: when the engine is in stopped position or the engine is running. Difference will be in the steps required to accomplish the whole procedure correctly, and safely operate the engine.

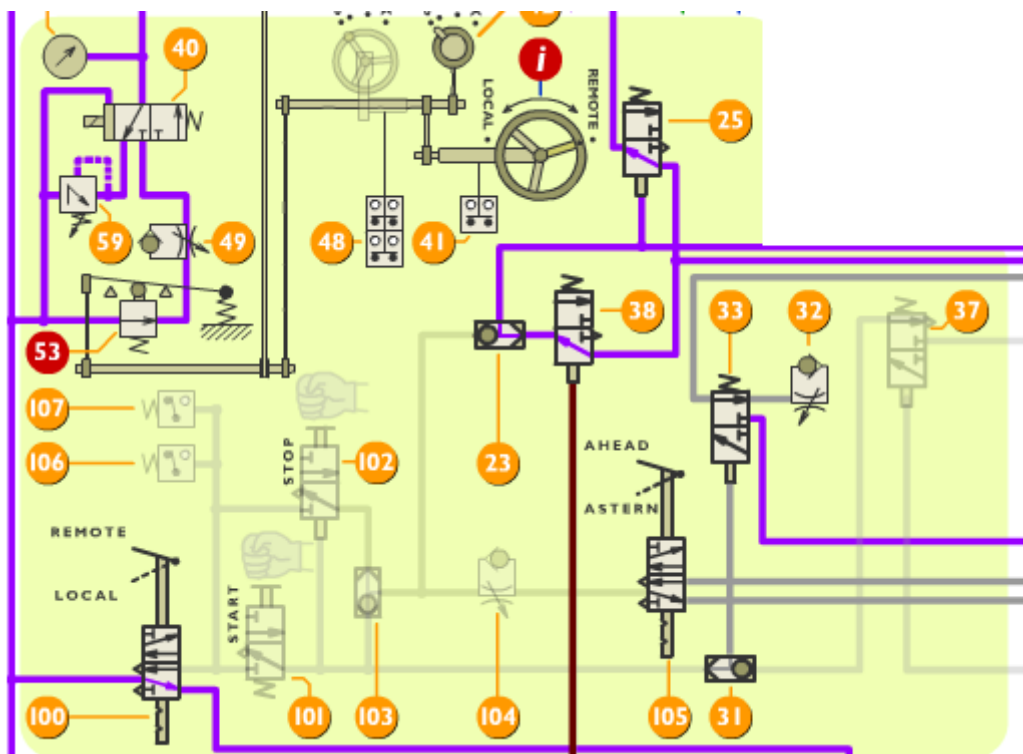

Figure 17 Engine local control console simulator schematic

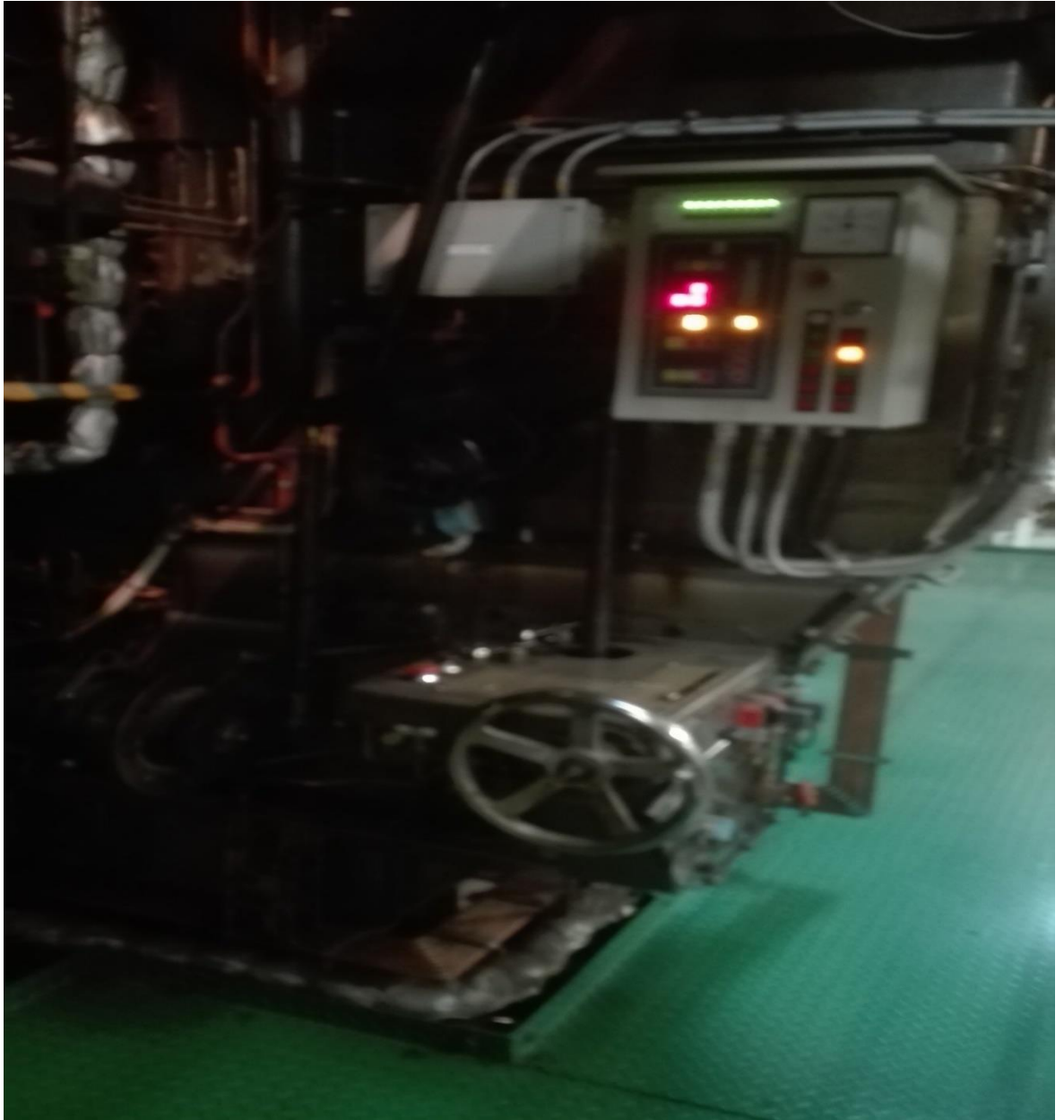

Figure 18 Engine local control console vessel MV NORDAUTUMN

5.2.1 Change-over with stopped engine

Engine is now stopped, and we want to change control from remote to local.

Step 1: Since engine will be operated from local console, crew on the navigation bridge must be informed. Reasons for local control must be explained, so they are informed about situation in the engine room. Communication between bridge and local console is to be tested.

Step 2: During operation in normal conditions, governor is a device which controls fuel pumps. Therefore, if the engine control is to be done locally, point from which fuel pumps are controlled must be changed. This is done by means of impact wheel. Now the fuel pumps are controlled manually by means of fuel regulating wheel (speed regulating wheel). Regulating handwheel must be moved into STOP position and impact wheel is set on LOCAL.

Step 3: Now the direction of rotation must be set. Manually can valve no. 105 be set into position for AHEAD or ASTERN.

Step 4: Valve 102 for stop signal must be opened since we need to prepare the engine for reversing and starting. Valve is in such position, that it can allow control signal to actuate: puncture valve on fuel pump, and valve 117 which is used to operate pilot valve for one cylinder on starting air distributor and depending on the position of valve 105 allows control air to reach starting air distributor and reversing mechanism of fuel pumps.

Step 5: Control of maneuvering system from REMOTE to LOCAL is done by changing position of valve 100. Position is to be set on LOCAL, thereby supplying air to valves for local control.

Step 6: At this point engine is ready to be started. First the speed regulating wheel must be set into MIN position. Starting valve no. 101 is activated (pressed manually) thereby sequence of starting initiated. Engine is started with compressed air impulse, up to a speed at which atomised fuel ignites readily in the combustion chamber. After releasing (closing) starting valve no. 101, valves no. 33, no. 38, no. 25, no. 117, no. 28 and no. 27 return to closed position.

Step 7. Engine is running at minimum speed and its speed can be increased by sending the speed signal to the fuel pumps directly by means of fuel regulating wheel, as ordered from the bridge.

Step 8. Stopping of the engine is done by activating the STOP valve 102. Control air actuates puncture valve and fuel injection gets terminated. Also, signal actuates valve 117, returning it to position of being ready to operate pilot valve, when engine is to be started again.

5.2.2 Change over with running engine

This situation is more delicate than the previous one and requires faster crew response. It can be a large safety risk, if during maneuvering remote control or governor breaks down. Only a crew who is well trained for emergency situations can respond effectively in such conditions.

Step 1: Same as in the previous situations. Position of control must be switched to the local control console near the engine. Bridge must be informed with giving reasons and engine speed set at 80 % MCR (Maximum Continuous Rating).

Step 2: Adjust LOCAL control for present running direction. If the engine is running in the ahead direction, air distributor and fuel pumps should be timed for that direction and vice versa, if astern is the current running direction. Valve 105 is to be put in position for AHEAD.

Step 3: In this step control of the fuel pumps must be changed from governor control to the LOCAL control at present speed settings. Blocking arm must be put to emergency position, regulating handwheel moved to align the tapered slots of fuel regulating system so that the fuel index setting will remain the same during change-over and quickly change-over from governor control to Fuel Regulating Handwheel with Impact Wheel. Regulating wheel goes to MAX position and Impact Wheel to LOCAL.

Step 4: Change over to LOCAL control is done by moving valve 100 into position where air is supplied to the valves no. 101 and no. 102 (for START and STOP).

Step 5: Since control is now switched to LOCAL, bridge must be informed that change-over is complete.

Step 6: By pressing the valve no. 102, air gets supplied to the fuel pump puncture valve and the engine is stopped. Regulating handwheel must be put into STOP position.

5.3 Crash stop manoeuvre

All the ships and especially large ocean-going vessels have large inertia force while their powerful engines are running - due to their enormous mass. When the signal STOP is given, and fuel injection terminated, ships continue to move in the same direction with slowly decreasing speed. There is potential risk for collision or running aground if the ship is in port, or at anchorage surrounded with other vessels. Unlike land transport, sea-going vessels don't have brakes that are supposed to stop the ship when needed. But if the full stop

of the ships speed is needed, like in the emergency situations, crash manoeuvring is performed. Ships's speed must be reduced quickly, so that the engine can be started into opposite direction of rotation. Operation is performed from Engine Control Room or Engine Local Console, so the controls are transfered from the Bridge to the Engine Room. The procedure is following:

1. Acknowledge the telegraph.
2. Then the STOP order is given. Fuel lever is brought into 0 position. The engine will continue to rotate (at slowly decreasing speed) because the velocity of the ship through the water, will drive propeller, and thereby turn the engine.
3. Limiters in the governor should be canceled, since this situation is not typical and requires the override of a system which protects engine.
4. When the engines speed has fallen to the point at which engine can be reversed (around 15-30 % maximum rpm (rotation per minute) depending on the ship size and engine type) following commands are to be given: a) Reversing order; b) Starting order
Now the pressurised air (30 bar) which can now be termed “brake air “instead of “start air” is introduced into the cylinders with purpose of slowing the engine furthermore.
5. After some time, engine will completely stop and begin to run into opposite directtio due to brake air force. When engine reaches 8-12 % MCR-speed give order to run on fuel.

When the manoeuver ends and the situation is under control, main engine detailed inspection must be carrier out, since this kind of engine operation is not common.

6. CONCLUSION

Starting air system is essential part of every engine. During manoeuvring in the ports, main engine is often reversed, started and stopped, so in that situations system is mostly used. During navigation, especially when the ship sailed over ocean for 15 or more days, it is recommended to test starting air system before entering the port. If the system has not been used in a while, and air dryer's efficiency had fallen, moisture could cause corrosion and make valves stuck. It is not convenient to have any problems with starting air system during manoeuvring. For the same reason system should be maintained by checking state of air dryer with filter and by draining air receivers on daily basis. Thorough knowledge of the system is expected from the marine engineering officers, so that reaction of the crew in emergency and unexpected situations is quick and correct. Systems spare parts should be always available in the engine room storage.

REFERENCES

- (1) <http://web.uom.ac.mu/Staffdirectory1/FT001000/LectureNotes/UTOSP%201261%20Set%201/Lecture%201&2.pdf>
- (2) https://www.festo.com/wiki/en/Air_in_pneumatics
- (3) <https://www.pneumatictips.com/what-are-pneumatic-valves/>
- (4) https://en.wikipedia.org/wiki/Dew_point
- (5) http://www.marinediesels.info/2_stroke_engine_parts/Other_info/MANBW_VIT_pump.htm
- (6) <https://www.marineinsight.com/guidelines/what-is-crash-manoeuvring-of-ship-in-emergency-situation-and-whats-its-procedure/>
- (7) http://www.marinediesels.info/Basics/air_start/automatic_valve.htm
- (8) Fran Bošnjaković : Nauka o toplini
- (9) Starting air system simulator
- (10) https://www.engineeringtoolbox.com/psychrometric-chart-mollier-d_27.html
- (11) https://en.wikipedia.org/wiki/Pressure_regulator
- (12) <http://dynamicsystems.asmedigitalcollection.asme.org/article.aspx?articleid=1413652>
- (13) <https://www.youtube.com/watch?v=Vfs7XUSgu24>
- (14) http://marengine.com/ufiles/SL03-415_907030086.pdf
- (15) http://www.marinediesels.info/2_stroke_engine_parts/Other_info/air_start_valve.htm
- (16) ME_Vol_1
- (17) Al_Rekayyat Machinery operating manual
- (18) Engine local control console vessel MV NORDAUTUMN

TABLE OF FIGURES

Figure 1 Mollier diagram (10).....	3
Figure 2 Air pressure reduction unit (11)	4
Figure 3 Pneumatic valve operated via solenoid (12)	5
Figure 4 Starting air distributor (13)	6
Figure 5 Starting air distributor (14)	7
Figure 6 Starting air valve (15).....	8
Figure 7 Main/automatic starting valve (7).....	9
Figure 8 Reversing mechanism (9).....	10
Figure 9 Fuel pump with VIT system (5).....	12
Figure 10 VIT mechanical-pneumatic mechanism (5).....	13
Figure 11 Starting air system (16).....	14
Figure 12 Compressed air system vessel Al Rekayyat (17).....	17
Figure 13 System when the engine is stopped (9)	17
Figure 14 Distribution diagram # 1 (9)	19
Figure 14 Distribution diagram # 2 (9).....	20
Figure 15 Reversing and starting (9)	22
Figure 17 Engine local control console simulator schematic (9)	23
Figure 18 Engine local control console vessel MV NORDAUTUMN (18)	24