

# Planning of Active Distribution Networks in Croatia

---

**Prenc, Rene; Strnad, Ivan; Tomas, Vinko**

*Source / Izvornik:* **Tehnički vjesnik, 2018, 25, 1867 - 1878**

**Journal article, Published version**

**Rad u časopisu, Objavljena verzija rada (izdavačev PDF)**

<https://doi.org/10.17559/TV-20171021131845>

*Permanent link / Trajna poveznica:* <https://um.nsk.hr/um:nbn:hr:187:033055>

*Rights / Prava:* [In copyright](#)/[Zaštićeno autorskim pravom.](#)

*Download date / Datum preuzimanja:* **2024-06-30**



**Sveučilište u Rijeci, Pomorski fakultet**  
University of Rijeka, Faculty of Maritime Studies

*Repository / Repozitorij:*

[Repository of the University of Rijeka, Faculty of  
Maritime Studies - FMSRI Repository](#)



# Planning of Active Distribution Networks in Croatia

Rene PRENC, Ivan STRNAD, Vinko TOMAS

**Abstract:** This paper explores the concept of distribution network planning in Croatia from both theoretical and practical point of view. First, the types of distribution system planning are presented. Then the technical criteria for distribution network planning in Croatia are elaborated, according to the Croatian Grid Code and the standard practice of Croatia's Distribution System Operator. The focus of this paper is to go through the basic differences between planning active and passive distribution networks in Croatia with special attention paid to voltage and power fluctuations caused by distributed generation units. Distribution network configurations that are used in Croatia are also displayed, especially in the context of redundancy and contingency analysis. The availability and type of input data for distribution network planning is thoroughly discussed. In addition, the paper addresses the challenges associated with the elimination of the 35 kV networks and the transition from 10 to 20 kV voltage level in Croatia. Finally, some relatively new but not yet exploited concepts are overviewed, like demand response and electric vehicles along with the future development of smart grids in Croatia.

**Keywords:** active distribution networks; distribution network planning and operation; distributed generation; network configurations; smart grids

## 1 INTRODUCTION

The planning of power distribution networks (DN) is a technical, geographical and economic analysis of different variant solutions with a goal of safe and reliable supply of electrical energy to the end consumers. Distribution networks in Croatia consist of low voltage (LV) and medium voltage (MV) networks. LV networks are operated on 0.4 kV voltage level, and MV networks are operated on 10, 20 and 35 kV voltage levels. The modern planning of distribution networks must satisfy many conditions, which often present a compromise between the requests of different entities on the power system market. The Croatian Distribution System Operator HEP ODS Ltd, which owns and operates the distribution network, must supply the growing electrical demand with minimal financial expenses [1]. On the other hand, consumers request that the quality of electrical supply is as high as possible [2]. Among many factors, this means that the reliability of electrical components (cables, overhead lines, transformers) must remain high and even in case of their malfunction, the electrical supply must be enabled to the end consumers from another feeding point (" $n-1$ " criterion). Finally, independent power producers (IPPs) require that the distribution network must accept the maximum output power from their distributed generation (DG) facilities in order for them to acquire maximal incentives via the feed-in tariff system. Due to the fact that the consumers can also be the producers of electrical energy on the electricity market, they are often termed as prosumers.

The problem that distribution system planners face is based on the uncertainty of a large portion of input data. In many cases the live measurements of electrical parameters like power, current and voltage are either not available or too scarce to form daily consumption curves. Furthermore, the future load points cannot be predicted and the connection requests must be dealt with in the moment as they come. Sometimes this will result in the oversizing of the network and at other times the network will be undersized. Thus the task of the distribution system planner is even more complex because he must determine not only the optimal but also a robust strategy of network expansion, in order to decrease a possible future mistake.

## 2 THE PLANNING OF DISTRIBUTION NETWORK EXPANSION AND OPERATION

The planning of distribution networks can be divided in two categories: the planning of DN expansion and operation. The DN expansion has a core function to supply new load nodes with electrical energy, but this also includes the connection of future DG units. Universally, the aim of DN expansion is the minimization of installation and operation costs of new substations, cables and overhead lines [3-5]. DN expansion can be enforced by using network analysis software (NEPLAN, ETAP, PowerFactory, etc.) where the main idea is to form the network in advance and then check its voltage/current constraints. However, recently there are other programs which build the network with minimal costs based on the input data concerning future substations and DG units (SwedPower, Hydro-Quebec, VDEW-ODIN, CADDiN, etc.). These programs combine the traveling salesman problem and vehicle routing problem with the load flow (LF) analysis to find optimal future network configurations.

On the other hand, operational planning is focused on the existing network and it includes all the activities that have a goal to improve its performance. For example, the installation of condenser batteries and the reconfiguration of the existing distribution network is done in order to cancel reactive power flows and to minimize line power losses respectively [6, 7]. Furthermore, deciding which MV/LV substations need to be equipped with remote control devices is also operational planning and it enables the DN dispatcher to quickly isolate the faulty elements. In that way he can promptly restore the power to the customers, thereby improving the quality of electrical supply.

Regarding the time horizon of DN planning, it can roughly be divided to short-term, medium-term and long-term planning [8]. Short-term planning usually encompasses the period of 3 years and its goal is to determine which elements (substations, cables/overhead lines) need to be constructed immediately, under the condition that the building permits are obtained for them. Medium-term planning refers to the period between 3 to 10 years and its goal is to initiate project management tasks

for new power system elements in order to acquire all the necessary permits needed for their commissioning. Finally, long-term planning refers to the period between 10 and 30 years and it is focused on setting the global directions of distribution network development. In practice, this means analysing and predicting the growth of electrical load and determining the macro location of new HV/MV substations, which constitute capitially intensive projects of high government interest. This must be done in advance especially in the urban areas since it is very hard to promptly acquire large parcels. Long-term planning may also determine the adoption of a new technology, like smart metering which will be carried out for all the customers in a long time period. The decision on transition from one voltage level to another is also covered and initiated in long-term planning analysis. The precise borders between short, medium and long-term planning have become blurred in the last decade due to the significant changes that have occurred in the Croatian power system. The changes, among many novelties, covered deregulation of the previous vertically structured power system, liberalization and opening of the electricity market for the private sector.

The starting point for initiating the distribution system planning is always the analysis of the current state of the existing network in order to accurately determine its strength to supply all the connection points in the future. The planning may be initiated with many internal or external factors. Overloading of the existing power system elements (HV/MV transformers, MV/LV transformers, MV and LV cables/overhead lines), breaching of the voltage constraints and the connection requests from new MV and LV customers or producers are just to name a few.

### 3 THE TECHNICAL CRITERIA FOR PLANNING OF DISTRIBUTION NETWORKS IN CROATIA

With the circumstances considerably changing in the last decades in the Croatian power system (deregulation and liberalization) and with the connection of power producers (starting from 2007), the once passive distribution network switched to an active network. A very important fact is that all these new moments occurred in a very short time span, meaning that the Croatian distribution system had to adapt quickly. During the last 10 years over 1500 DG units with a total of approx. 160 MW have been connected to the Croatian distribution system. It is also interesting to describe the current state of the complete power system in Croatia. The Croatian power production mix has a 3.745 GW of total capacity, of which 2.079 GW (55 %) are hydro power plants. Total installed power of renewable energy sources and cogeneration plants in the T&D network of Croatia in 2016 was 449.5 MW, of which wind power plants constituted vast majority (over 75 %). Wind power plants generally connect to the transmission network due to their high installed power. The peak power consumption in Croatia in 2015 was 3.009 GW, measured at 13:00 h on the 22<sup>nd</sup> of July [9].

The technical criteria for DN planning in Croatia are based around the voltage and current constraints, which must not be breached in normal and abnormal operation. First, the rules for normal operation will be covered. This basically means that all the prosumers draw/produce electrical energy under normal circumstances. There has

been no outage of any electrical element and all the technical parameters are in-range. Each element like transformer, cable and overhead line must not be overloaded (>100%), and the voltage of each part of the network must be kept in conformity with EN 50160 (the European Standard on Power Quality). The EN 50160 norm (issued in 1994 by CENELEC) defines voltage tolerances on the LV and MV level as  $\pm 10\%$  of rated voltage in 95 % of time of 10-minute measurements within a week. The latter criteria are covered in a document which defines the rules of Croatian power system operation, called the Grid Code [10]. This voltage criteria define both voltage rise and voltage drop boundaries in the network. Voltage rise is of course caused by distributed generation while drop is caused by regular consumption. However, the Croatian DSO has stringent rules for voltage constraints and it addresses only the voltage drop, which must not be lower than -8%. This is done in order to immediately start the remedy actions when the load flow analysis shows that the voltage drop has breached 8%. Since replacing or laying of new cables/overhead lines, then replacing transformers or building new substations requires extensive project documentation and the time to obtain the building permits, then the remedy actions must start well below the  $\pm 10\%$  limit.

The second state is abnormal operation (referred to as the " $n-1$ " state), which occurs during a fault of one network element. It is called the " $n-1$ " state because in case of a single element failure the backup supply must be ensured for a customer (or a group of customers) with peak consumed power of >1 MVA [11]. For example, if a single MV line experiences a fault, then first it must be isolated on both sides with corrective switching manoeuvres. Then, if it is possible, the supply will be ensured from another feeding point (HV/MV substation) and it will last until the line is repaired. This is abnormal operational state since the DN is reconfigured. Due to the reason this state is not supposed to last long, the current and voltage limits are broadened. In abnormal operation overhead lines and transformers can be overloaded 120% in the winter season and 110% in the summer season. However, cables must not be overloaded more than 100% even in abnormal power system operation. In addition, the voltage of each part of the network must be kept within + 10%/-15 % boundaries of rated voltage. Like before, the Croatian DSO has stringent rules for voltage constraints and it addresses only the voltage drop which must not be lower than -12%. Finally, the " $n-1$ " criterium is actually DSO's obligation to provide supply in abnormal operation caused by the loss of only one component (MV line or HV/MV transformer). If the consumer wants " $n-2$ " redundancy, then he has to cover the costs of the network upgrade. The " $n-1$ " criterium is valid only for MV networks and will be further explained in the 5<sup>th</sup> chapter.

It is interesting to note that in the new circumstances DG units can be used to ensure the " $n-1$ " state. However, only DG units with constant primary energy source can be used (power plants operated on biofuels or biomass), and the intermittent sources like wind or solar power plants cannot be used. In case the network experiences a fault, DG units can take some of the load by operating in the island mode. The island mode however needs to be regulated before between the DSO and the Independent Power

Producer (IPP) via bilateral contract. This must be done in advance since for now the practice in Croatia is that IPPs can shut down their facilities at will (though first they need to inform the DSO). The IPPs have no responsibility toward the network customers. Also, the technical parameters of the island mode need to be known in advance, since the DG can take only the total load below its installed power. In case it takes over too much load, it is under frequency protection and will shut down the unit and the island mode will go off together with the supply for the customers. Also, when the damage is repaired and the original network is restored, the island needs to be synchronized with the grid. Opposite will cause a new and potentially dangerous fault for the generator in the production facility. For now DGs in Croatia do not ensure "n-1" state, neither do they operate in the island mode.

#### 4 COMPARISON OF POWER FLOWS AND VOLTAGE PROFILES OF A PASSIVE AND ACTIVE DISTRIBUTION NETWORK

The traditional distribution network was designed for a unidirectional power flow from the source (HV/MV substations) to consumers and was built to meet only the requirements of the consumer load. An example of a typical passive Croatian MV network operated on 20 kV and fed by a 110/20 kV substation is demonstrated in Fig. 1.

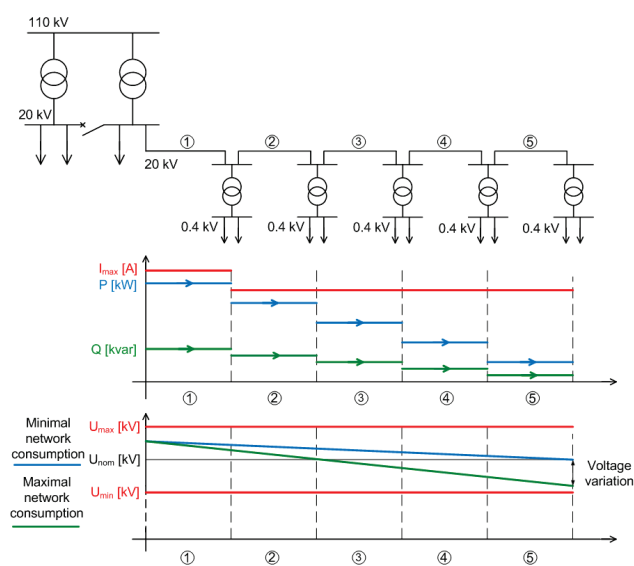

Figure 1 An example of load flows and voltage profile of a passive MV network

On a radial feeder of a passive distribution network, active and reactive power flowing through the cables and/or overhead lines reduces towards the end nodes of the feeder. As a consequence, the lines closer to the beginning of the feeder are heavily loaded and generate higher losses than the lines near the feeder's end, as displayed in Fig. 1. For that reason the beginning lines have the highest cross-section and in Croatia this is usually 185 or even 240 mm<sup>2</sup> for MV cable networks fed by 110/20 kV substations. Other lines have a uniform 150 mm<sup>2</sup> cross-section, but this is reserved only for cable networks. In Figure 1 this is displayed by a red line denoting  $I_{max}$  which is the highest for line 1 and uniform for lines 2-5. The MV networks consisting of overhead lines have many diverse cross-

sections, but the general rule which refers to the heavier loading of the beginning lines still applies here.

The connection of a new load node in a MV distribution network is immediately followed by the increase of the current from the feeding HV/MV substation towards all the nodes of the network. Also, the increase in current is associated with a proportional voltage drop, which becomes greater towards the end nodes of the radially operated distribution network. One however important distinction must be made between a lightly loaded network and the network under full load. In the first case the voltage drop will not be as high as in the second case due to a lower load current. If the difference between light and heavy load is significant, then the voltage variations for all the nodes in the network can have quite a broad range, as displayed in Fig. 1. The variations will especially be highlighted at the end node of the feeder. In extreme cases these large differences may occur during a single day between light load at night time and heavy load at day time, but it is more common in Croatia that these variations are seasonal and not diurnal.

The voltage on a MV side of a 110/20 kV substation is regulated with an OLTC device (on-load tap changer) which alters the power transformer turns ratio in a number of predefined steps and in that way changes the secondary side voltage. This is done online and no network interruption is needed to change the tap positions. Standard tap changers offer between  $\pm 10$  steps (i.e. 21 position, including zero position), with each step representing a change in 1.5% nominal voltage. Thus the voltage on the MV busbars can be regulated by  $\pm 15\%$ . In practical cases, the voltage on a secondary side of 110/20 kV substations is fixed and maintained at approx. 21 kV to compensate a possible large voltage drop in the 20 kV network.

The same physical principles explained in the previous paragraphs apply for LV distribution networks fed from MV/LV substations. One important difference is that the voltage on a LV side of a 10(20)/0.4 kV transformer is regulated with an NLTC device (no-load tap changer) which means that the transformer must be de-energized before the turn ratio is adjusted. Standard tap changers offer between  $\pm 2$  steps (i.e. 5 positions, including zero position), with each step representing a change in 2.5% nominal voltage. Thus the voltage on the LV busbars can be regulated by  $\pm 5\%$ .

However, an occurrence of reverse power flows can happen in passive MV networks but only under certain conditions. The reverse reactive power flows accompanied by voltage rise along the lines are possible for two different cases. The first case concerns very long and unloaded cable networks. For example, the Croatian island Krk has a very long cable network fed by two 110/20 kV substations and outside the summer (tourist) season this network is operating with a very low load. Since the long cables have a significant cumulative capacitance, they produce reactive power and sometimes can cause reverse reactive power flows. The second case refers to MV customers which buy condenser batteries for power factor correction of their internal MV and LV networks. This is done in order to reduce electrical bills, since the reactive power is charged to all industrial consumption. In case the consumer closes (or relocates) his industrial facility and the condenser batteries are not shut down (or relocated), they will

continue to generate reactive power and as a consequence the voltages of that particular feeder will rise. Unlike the example of a very long and unloaded cable network, this occurrence is localized only to the feeder which contains condenser batteries.

With the introduction of DG units, the concept of planning and operation of the distribution network drastically changes [12]. The DN loses its main and distinctive feature of radial operation and unidirectional power flows while in the same time the DG units cause higher loading of some network lines which were supposed to carry lower currents. According to the Croatian Grid Rules, the DG units with the output power <500 kW connect to the LV network and the DG units with output power >500 kW and <10 MW connect to the MV network.

An example of an active MV network operated on 20 kV and fed by a 110/20 kV substation is demonstrated in Fig. 2. It can be seen that now the DG unit produces active power for the whole feeder, while reactive power is still supplied from the 110 kV network via the 110/20 kV transformer. The fact that DGs do not produce or consume reactive power is often true in practice, since most DGs connected to either MV or LV network operate with unity power factor ( $\cos\varphi = 1$ ) in order to deliver as much of active power to the network as possible. The reason for unity power factor operation is to obtain maximal incentives which are ensured by the feed-in tariff system which is still present in Croatia. Incentives are of course paid for delivered active power in kn/kWh and they depend on the type of DG unit [13]<sup>1</sup>.

In these new circumstances line 1, which was the most loaded in passive network (Figure 1), is now drastically unloaded and carries only reactive power for the whole feeder. On the other hand, line 4 is more loaded than in the previous case. Lines 2, 3 and 4 have reversed power flows and the directions of active and reactive power is opposite, as is displayed in Fig. 2. The lines after the DG unit have the same power flows as in the passive network.

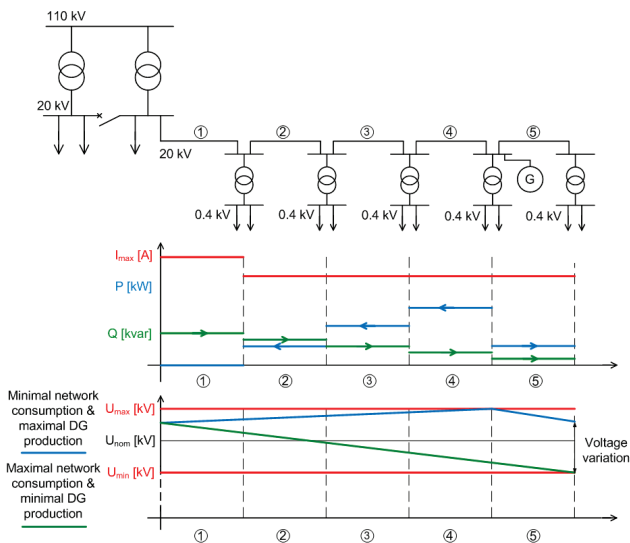

Figure 2 An example of load flows and voltage profile of an active MV network

In case the peak produced power of DG is lower than the sum of all the loads in the feeder, the reverse power flows will be localized to the feeder and electrical losses,

proportional to the square of line current will drop compared to the passive network. This situation is the most favourable for the DSO from the planning and operational point of view. However, if the peak produced power of DG is greater than the sum of all the loads in the feeder, then the electrical losses may rise compared to the passive network, and the line 1 will transfer active power in the opposite direction. That power will not flow towards the 110/20 kV transformer, but will first feed the neighbouring feeders. The 110/20 kV substation usually has 20-25 feeders, divided in two sections. Each section is fed with its associated transformer. Only if the cumulative produced power of all DGs is greater than the cumulative demand of all the feeders, will the active power actually flow through the 110/20 kV transformer and upstream to the 110 kV network. In practice this rarely occurs in Croatian MV networks since the MV connected production facilities are scattered throughout the entire system. Also, their total number is much lower compared to the DGs connected to the LV network.

However, the upstream power flows do happen in LV networks due to the reason that in practice more than one DG unit can be connected to the same MV/LV substation. Since the biggest 10(20)/0,4 kV substations in Croatia have capacity of 2×1000 kVA and more DG units (each of up to 500 kW) can connect to those substations, then this scenario is entirely possible during light load. Not only can the combined power of DG units cover all the LV feeders, but its surplus can go upstream the transformer and to the MV network. For that reason, the Tariff System for the Production of Electrical Energy from Renewable Sources and Cogeneration Plants in Croatia defines that IPPs which own PV systems connected to the LV grid will receive incentives only for the produced energy which covers the IPP's total monthly load. The surplus energy going to the LV grid will receive a much lower incentive. For example, a customer owning a house with a monthly consumed 500 kWh of electrical energy wants to connect a PV system with installed power of 20 kW. The total monthly produced energy of 500 kWh by the PV will be stimulated with 1.70 kn/kWh, but the additional energy (surplus) with only 0.53 kn/kWh.

Although reverse power flows are not desirable for DN operation, they cannot serve as a reason for stopping the connection request for a new power producer. However, if the preliminary load flow analysis shows that DG causes overloading of some network elements, then this is a good enough reason in practice to either cancel the connection or define network upgrades which must be entirely covered by the IPP's financial budget. The most common limiting factor for DG connection in Croatian networks is usually breaching of  $\pm 10\%$  voltage constraints caused by the introduction of DGs. In an active distribution network, the voltage rises from the beginning of the feeder toward the Point of Common Coupling (PCC) of a connected DG. After the DG and towards the end of the feeder the voltage drops, as is displayed in Fig. 2.

There are 2 possible extreme cases concerning the voltage profile of an active network. The first is related to the maximum loading of the network, while the DG unit produces no energy. This can happen due to a planning

<sup>1</sup> 1 € equals approx. 7.5 Croatian kunas.

maintenance or a fault experienced by DG, or even as a part of standard DG operation. The latter occurs during the night for photovoltaic (PV) power plants. Sometimes the DG unit can even consume power from the network. For example, the PVs consume power from the grid during the night (or a cloudy day) for the operation of its DC/AC converters (inverters). If the DG consumption coincides with maximal loading of the feeder, the voltage drop will be even more emphasized than in the passive network and may lead to breaching of voltage limits. On the other hand, if the DG maximal production coincides with minimal loading of the feeder, the voltage rise may climb to unacceptable values. The voltage variations for all the nodes in the network will have much broader range compared to the network without a DG unit, as is displayed in Fig. 2. This time the variations will especially be highlighted at the connection point of the DG (PCC).

The DG unit can be actively used to improve the voltage profile of the feeder by the production or consumption of its reactive power. Automatic voltage regulator (AVR) detects the voltage of the PCC and adjusts the DG's reactive power output in order to maintain the voltage of the PCC in pre-set value. However, since DGs usually work with constant unity power factor, this is done only for DG units that have a significant power output which causes great voltage oscillations in the associated feeder. In the latter case a bilateral contract must be made between the IPP and DSO in order to precisely define the parallel operation of the DG with the network. Croatian Grid Rules define that the DG units should be able to produce reactive power in the limits between  $0.85 < \cos\phi < 1$ . However, this does not apply to PV systems, meaning that they do not have to be used to improve the voltage profile of the network. On the other hand, wind farms with induction (asynchronous) generators must be equipped with their own compensation facilities (condenser batteries) so that the average value of power factor is 1 with maximal offset of 0.1 in inductive or capacitive range.

In short, the IPPs will not be financially compensated by the DSO as long as their DGs produce power with  $\cos\phi$  inside the defined boundaries. It can also be noticed that for now the Croatian Grid Rules do not allow the operation of DGs with a capacitive power factor (the only exception are wind farms with induction generators). This operation could be useful for long and lightly loaded lines, where a DG unit would cause a significant rise in voltage. The consumption of reactive power by the DG would lower the voltage to the required  $\pm 10\%$  limits, but for now this is not covered by current legislation. The Croatian Grid Rules have been published in 2006 and by now have become obsolete. It is expected that new rules covering distribution networks will be published in 2018.

Finally, it can be generally concluded that DG units can enhance the voltage profile, especially in cases where voltage drop is very severe due to the high loading of the associated feeder. Then the connected DG unit can simply return the voltage parameters of every node in the feeder into its respective boundaries ( $\pm 10\%$  of  $U_n$ ). However, this DN operation improvement is only reserved for non-intermittent DGs, like biomass or biogas fuelled power plants. Wind-farms or PV systems cannot guarantee voltage improvement, since their peak production does not have to coincide with the feeder's maximal consumption.

PVs have maximal production during the midday hours, while the residential consumption is usually the biggest in the evening hours. This means that connecting a PV unit will not solve the problem of a high voltage drop, and may consequently cause large voltage variations during a single day. As a consequence, new consumers or producers who wish to connect to the same feeder will not be able to do so until the network is upgraded, which means they must (partly or completely) finance those upgrades. In other words, the feeder becomes sterilized for future consumers and producers since a new connection point may break the  $\pm 10\% U_n$  rule. For that reason it is necessary to encourage the connection of new DG units with optimal installed power on optimal locations in the distribution network [14]. Lower power losses, investment deferral and voltage profile improvement are just some of the benefits associated with optimal allocation of DG units [15-19].

## 5 DISTRIBUTION NETWORK CONFIGURATIONS IN CROATIA

Distribution networks in Croatia are radially operated without exception, but their configuration can either be radial or meshed. Radial configuration is characteristic for all LV networks and MV networks in rural areas. That simply means that all the outgoing feeders radially branch out from the feeding substation and are not mutually connected. In Fig. 3 a radial MV network with 2 feeders is displayed, with the upper feeder containing a lateral branch.

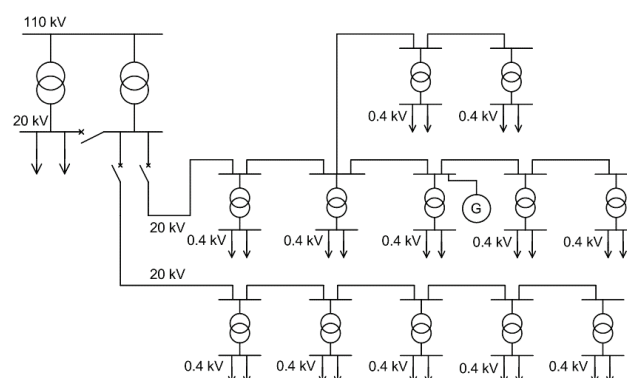

Figure 3 An example of a distribution network with radial configuration

However, there is a significant difference between a MV and LV radial configuration. The MV feeders have only one protection device (circuit breaker) and it is located in the MV switchboard at the feeding substation (beginning of the feeder). In case of a fault anywhere on the feeder, the breaker trips and all the MV/LV substations (and customers) on this particular feeder are left without power. When the fault is isolated (e.g. faulty line) the power can only be restored to the MV/LV substations located before the isolated element. All the customers located after the isolated element are faced with blackout during the repair time. Depending on the severity of the fault this can take a considerably long time.

However, the "n-1" criterion can still be applied, but only for one situation which involves the fault or a maintenance of the HV/MV transformer. If the feeding substation has 2 HV/MV transformers (in Croatia this is the most common case), then the other one can take over the

load after closing the tie-breaker between the MV sections. In order to accomplish this operation during repair time, the HV/MV transformer which has taken the additional (and significant) load must have enough capacity for this task. Typical 110/20 kV substations in Croatia are equipped with 2×20, 2×40 or even 2×63 MVA transformers.

Every blackout lasting longer than 3 minutes is considered as a long-time supply interruption in Croatia. For now this is not sanctioned according to Croatian legislation and the DSO will not be penalized for low reliability indices (SAIFI, SAIDI). But, since Croatia is a member of EU and it must accept its Directives concerning electrical energy market, this will change in the near future.

On the other hand, LV feeders do not have a uniform cross-section of cables/overhead lines. That means that they do not have only one protection device (fuse) located at the beginning of the feeder, but also the additional fuses are placed on each line with a different cross-section. For example, suppose the feeder has a total of 5 lines, with 3 lines having 150 mm<sup>2</sup> and the last two 35 mm<sup>2</sup>. Then one fuse will be located at the beginning of the feeder and the other at the beginning of the 4<sup>th</sup> line. This concept ensures current selectivity and improves SAIFI and SAIDI indices while it is not expensive at the same time. The downside is that all the LV networks have a radial configuration, meaning the supply cannot be ensured by means of another feeder with appropriate switching manoeuvres. In other words, all the customers located after the isolated element are faced with blackout during the repair time. The reason for not having a backup supply on LV networks is that losing one LV feeder cannot be compared to losing one MV feeder, since the number of customers depending on the latter is by far greater. Thus, it would be economically unjustified to ensure backup supply for LV networks.

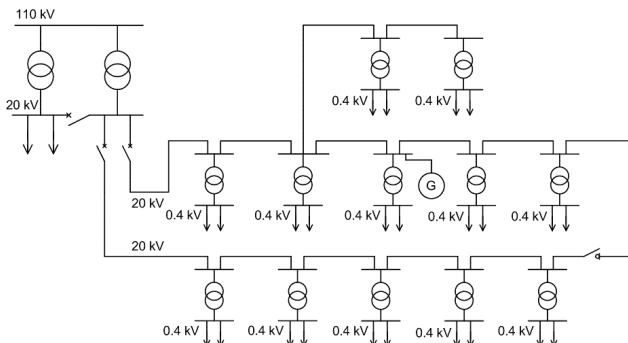

Figure 4 An example of a distribution network with ring configuration

Besides radial configuration used in all LV networks and rural MV networks, a characteristic MV configuration used in urban areas is called a meshed configuration. Its main feature is that in the case of a fault on one feeder, the electrical supply can be ensured from other feeders. Meshed configuration can further be divided to ring and interconnected system configuration. Ring or loop configuration simply means that the outgoing feeders branching out from one substation are mutually connected. In Fig. 4 a MV network is displayed with 2 feeders connected with a tie-line between the end nodes. This line does not carry current in normal operation, and is opened on one side with a switch disconnector which is located in the MV switchboard of its neighbouring MV/LV

substation. The tie-line is still live and it must not be opened (isolated) on both sides, because in that case the DN planner would have no information about its status. Any tie-line fault would simply go undetected, meaning that its backup capability would be diminished and no one would know what happened.

A very important fact must be emphasized regarding the operation of the feeders. Both feeders remain radially operated, but in case of a fault on one feeder, the electrical supply can be restored from the other feeder by simply isolating the faulty element (e.g. line) and then closing the switch disconnector. In this abnormal operation overhead lines and transformers can be overloaded 120% in the winter season and 110% in the summer season. However, cables must not be overloaded more than 100%. More important, the voltage of each part of the network must be kept within + 10%/–15% boundaries of rated voltage. The most severe situation is when the first line of a feeder experiences a fault, because then the voltage and current constraints may be breached during backup operation. Distribution system planners always check this state as a part of offline load-flow contingency analysis. Finally, if the lateral branch experiences a fault, then the power cannot be restored to the MV/LV substations located after the isolated element.

This topology is especially suitable for peripheral urban regions, where it is necessary to close the MV loops without building new HV/MV substations. It is important to conclude that the ring configuration will definitely raise the reliability indices (SAIFI, SAIDI) compared to the radial configuration. However, in case of a complete HV/MV substation shut-down, all consumers will be affected by the blackout.

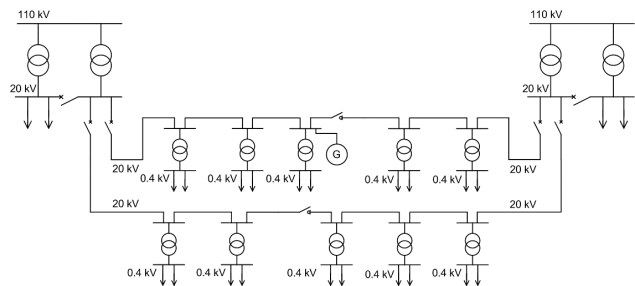
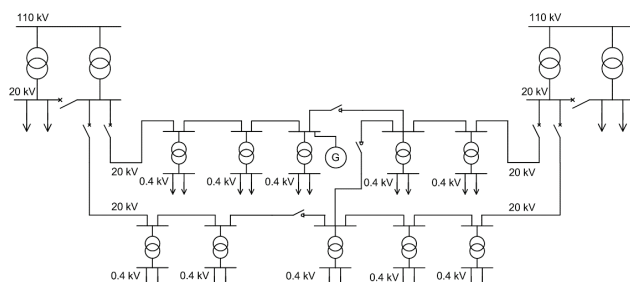

Figure 5 An example of a distribution network with interconnected system configuration

On the other hand, the main characteristic of the interconnected system configuration is that the outgoing feeders which branch out from two or more HV/MV substations are mutually connected. In Fig. 5 a MV network is displayed with two HV/MV substations and 4 feeders connected by tie-lines. Of course all four feeders remain radially operated, but in case of a fault on one feeder the electrical supply can be restored from the other HV/MV substation by simply isolating the faulty element (e.g. line) and then closing the switch disconnector. As stated before, in this abnormal operation current and voltage boundaries must not be breached. The backup supply for all the consumers can be ensured even in case of a complete shut-down of one HV/MV substation.

The topology that is mostly used in Croatian cities is a combination of the ring and interconnected system configuration, as displayed in Fig. 6. It is similar to the

previous configuration displayed on number 5, but has additional MV tie-lines connected between MV/LV substations of different feeders. This combination offers the greatest redundancy and the highest reliability indices (SAIFI, SAIDI) because the backup supply can be ensured from more than one feeder from another HV/MV substation. In addition, with appropriate switching operation the power can also be restored by other feeders of the same HV/MV substation (loop operation). Also, MV/LV substations with tie-lines are remotely operated in practice (usually via optical communication lines), in order to hasten the switching manoeuvres.



**Figure 6** An example of a distribution network with combined ring and interconnected system configuration

## 6 THE INPUT DATA FOR DISTRIBUTION NETWORK PLANNING IN CROATIA

The input data for planning of distribution networks can be divided into exact data which is measured directly or available via manufacturer's catalogues, and the estimated data which is not directly measured or available.

A detailed information on the type of transformers, cable/overhead lines and other electrical elements can be found inside the manufacturer's catalogues (ABB, Siemens, Schneider, Elka, etc.). For distribution system planning only the data on the capacity (carrying current), impedance and cable/overhead line length is important, since those are the input parameters of each load flow analysis.

The most important information for conducting the aforementioned calculations regards the data on electrical load. These data can only partially be obtainable by direct measurement. The Croatian DSO has metering equipment that actively measures in real-time the electrical parameters (current, voltage, active, reactive and apparent power, etc.) inside the feeding substations 110/10(20) kV, 110/35kV and 35/10(20) kV. The numerical relays obtain the data via voltage and current transformers (VTs and CTs) located at the MV switchboard. Each MV section has one VT (there are usually two MV sections in a HV/MV substation) and each MV feeder is equipped with its CT (there are usually 15-25 MV feeders in a HV/MV substation).

However, after connecting a DG unit, the measurement of the feeder input current does not represent the real value of the total load. This is because a part of the feeder load is supplied by the aforementioned DG unit. Also, the consequence of DG connection on the MV network is that the AVR device, which regulates the tap positions of the HV/MV transformer, can malfunction. This happens because the AVR registers the lower current of the feeder (although that current covers only part of the load) and in response it automatically lowers the voltage of

the entire MV busbars. That means that all the remaining MV feeders will have a lower voltage at their beginning, even if they are already highly loaded. In that case their associated voltage drop can break the EN 50160 norm.

Unlike the HV/MV transformers, most MV/LV transformers in Croatia have a rudimental electromechanical device for load registration. It is basically an ammeter connected to the secondary side of a CT which has two pointers. Its main purpose is to visually display the amount of current flowing through the transformer, which can be monitored by simply watching the pointer move on the panel. Of course, it cannot store load curves of the substation area, and it cannot measure active, reactive or apparent power. However, if the load of the substation has risen to a new peak, the other pointer (usually coloured in red) will remain locked in that position. This serves as the most important information for the planners when deciding the optimal time to acquire a new transformer with bigger capacity. There are examples of installing a measurement terminal inside the MV/LV substations with advanced capabilities, but since this is a costly solution and involves building the communication infrastructure towards the DSO's headquarters, it is used only as a part of smart grids pilot projects. The lack of adequate measurement devices for measuring and storing power consumption curves is a problem because any detailed power flow analysis will simply be incomplete.

On the other hand, all the MV customers connected directly to the Croatian MV network are equipped with automatic meter reading (AMR) devices that can measure and store daily consumption curves. The same applies to LV customers with power over 30 kW. However, households <30 kW are not yet equipped with new digital AMR devices and they constitute around 99 % of the total number of metering devices in Croatia. That presents a problem not only for predicting the future growth of consumed power, but also for determining the exact amount of balancing energy. Since all electrical supplier companies on the electricity market are responsible for deviations between realized and scheduled values of electrical power, they should correctly assume the future consumption of its customers. According to the General Conditions for Network Usage and Electrical Energy Supply, the DSO is obligated to introduce the AMR system to all the households in the next 15 years, but until then this problem remains unsolved [20]. It is interesting to note that, although only 1 % of the total number of metering devices in Croatia is equipped with AMR, these devices register 43 % of the total consumed energy in Croatia. This is because the AMR equipped customers are HV, MV and LV industrial consumers and companies which draw significant amount of power from the grid.

The main problem of not having the information on hourly consumption of all the customers in the distribution network is that the planner cannot correctly conduct a load flow analysis for 24 hours in order to quantify the electrical losses in the grid. Performing load flow analyses with peak loads was characteristic for passive distribution networks, but in active networks it cannot be used to the same effect because the consumption and production do not necessarily coincide in time. Of course, roughly two LF scenarios are mandatory for every planning study and they concern the situation with maximal production and minimal load and



the situation with minimal production and maximal load. But, since the DSO is responsible for covering its network's losses, it must correctly estimate them in order to buy the appropriate power on the electricity market. Furthermore, estimating losses without using 24-hour production and consumption curves may lead to a situation where the planner has an impression that a DG unit is lowering the feeder's losses, while in reality it is doing the opposite. The integration of PV units in a distribution network is one example where 24-hour load flows should be mandatory for this task.

Finally, the last necessary information for distribution network planning is the estimation of future load growth. This is probably the most difficult task since it covers both the existing and future MV and LV consumers and producers. The estimation of load growth of existing MV/LV substations can be done by many forecast techniques. Most of them are based on historical data combined with the prediction of economic growth in Croatia. Due to the recent economic crisis, the Croatian distribution system has overall faced stagnation in the last couple of years. Only coastal areas by the Adriatic Sea have experienced more intensive load growth, but even that is not above 3% per annum.

When a future MV or LV customer delivers a request for connection, he/she only provides the information on the peak power that will be consumed. This is good enough if the planner only needs to investigate whether the distribution network must be upgraded to enable this connection. If the upgrades are not required, then a MV or a LV customer must pay a sum proportional to its requesting active power ( $C = c_{LV/MV} \cdot P_{req}$ ), where  $C$  is the total financial expenditure,  $c_{LV/MV}$  is the unit price in kn/kW and  $P_{req}$  is the active power requested by the consumer from the DSO. On the other hand, if the upgrades are necessary, then a MV or a LV customer is billed in the following way. The payment is calculated by the above formula in all situations except when the real connection costs (costs of new substations, new cable laying or cable replacement, etc.) are over 120% of the amount calculated by the previous formula. In the latter case the consumer must pay those connection costs which are calculated in proportion to its connecting power. For example, in order to provide the LV customer's new house with 20 kW, a MV/LV substation with 50 kVA installed power needs to be built along with its MV connection lines. The consumer will either pay the amount defined by the previously stated formula, or in case the real connection costs are over 120% of the calculated amount, he will finance those costs. That means he will finance the construction of new MV connection lines and the substation in proportion of  $(20/50)\% = 40\%$ . Additionally, he will pay 100% of the costs covering the construction of the LV line from the substation to the house. This is an example of a partial deep connection charge stated by the DSO.

When a future MV or LV producer delivers a request for connection, he/she also provides the information on the peak power that will be produced. However, unlike with the consumer, a producer has to cover 100% of the connection costs on the voltage level he is connecting to, together with 100% costs of network upgrades on a higher voltage level (if necessary). This is a clear example of a complete deep connection charge stated by the DSO.

Although these double standards do not seem fair for the producer, the idea is that these (potentially huge) costs act as a natural filter to discourage the connection of DG units with high power compared to the local load. Furthermore, since the feed-in tariffs last for 14 years in Croatia, the DG units may become infeasible after that period, meaning that the IPPs may shut them down. In that case the network reinforcement will not be justifiable, because the grid will be over dimensioned.

As a conclusion, it would be of extreme use that the future customers and producers provide at least the estimation of the daily consumption/production curves for their future installations. Having that information, the planner could reconfigure the network in order to minimize the losses immediately after the connection. Unfortunately, without that information the planner needs to wait until he obtains a larger sample of the production/consumption data via metering devices, before he can start the reconfiguration analysis.

## 7 THE ELIMINATION OF THE 35 kV NETWORK AND THE TRANSITION FROM 10 TO 20 kV OPERATING VOLTAGE

Before the 1970s, Croatia's MV power distribution system was comprised of 35 and 10 kV networks, fed by 110/35 kV and 35/10 kV transformers respectively. Transformers 110/35 kV were the link to the Croatian Transmission system, which was and still is operated on 110, 220 and 400 kV. However, from the 1970s onward, the goal in Croatia is to eliminate the 35 kV network and replace the 10 kV with a 20 kV network fed by 110/20 kV transformer substations. This goal is displayed in Fig. 7.

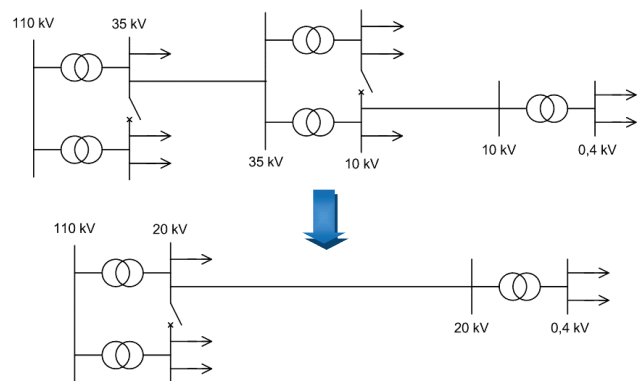

Figure 7 The concept of the MV network development in Croatia

The advantage of using 20 kV over 10 kV is that the line capacity is doubled, because a 185 mm<sup>2</sup> cable with approx. 350 A carrying current can transfer approx. 6 MW on 10 kV and 12 MW on 20 kV voltage. This is a huge advantage, meaning that the load growth in the future can be covered with the network transition from 10 to 20 kV voltage instead of building new MV distribution feeders and substations. Also, the line currents in the 20 kV network will drop by half compared to the 10 kV network, which will not only unload the lines but will also lower the voltage drop across those lines by four times. The 20 kV network line losses will be reduced four times compared to the 10 kV network, since they are proportional to the square of the line current. Furthermore, the maintenance costs will drop due to the lower number of feeding

substations. One possible downside is that the capacitive currents will be twice as big as compared to the 10 kV network because they are directly proportional to the operating voltage. For that reason it will be mandatory to ground the secondary side of the 110/20 kV transformers via neutral earthing resistor (NER). In comparison, the 35/10 kV substations which feed the 10 kV networks usually have a total capacitive current  $<20$  A. For that reason the transformers in those substations are ungrounded.

Before the 20 kV medium voltage network is introduced, all the 10 kV cables/overhead lines and substations need to be prepared for 20 kV voltage and the 35 kV network needs to be abandoned. In practice this is done gradually and is solved on the case by case basis in each Croatian region. There are however some global rules. In general, 110/35 kV substations will modify their 35 kV switchboard to accommodate 20 kV. This will be accompanied by the gradual replacement of 10 kV lines in the substation's supply area with 20 kV lines. For the overhead lines this is much easier, because the poles can be kept and only the insulation must be upgraded. However, the cables that cannot be operated on 20 kV must be replaced by the ones that do. Also, 10 kV MV switchgears of 10/0.4 kV substations must be replaced to accommodate 20 kV voltage level. At the beginning, the complete network will be operated on 10 kV until the last cable/overhead line and MV/LV substation is prepared for 20 kV voltage. Only then will the entire supply area switch to 20 kV. Since one 110/20 kV substation with a capacity of  $2 \times 20$  MVA can replace two 35/10 kV substations with  $2 \times 8$  MVA, the latter will be shut down after the start of 20 kV operation.

The existing MV customers already connected to the 35 kV network have purchased the right to higher amount of power and will remain fed by the 35 kV feeders in the future, since 20 kV voltage would not transfer enough power for their needs. These customers are scarce, but as said, 35 kV feeders will be kept for them and 110/20 kV substations will have an additional 110/35 kV transformer to supply them in the future. Thus the 35 kV will not be eliminated completely. Other 35 kV lines can safely operate on 20 kV voltage (because of increased insulation level) and, where possible, they will be interpolated as a part of the 20 kV network.

As said, the 35/10 kV substations will be shut down, but they can also be used as 20 kV switching stations (without the voltage transformation) or can even be upgraded to 110/20 kV substations. The last two solutions are rare, but they do occur in practice. Using a 35/10 kV substation as a 20 kV switching station can be a good idea in order to supply a remote area with electric power after the transition of the network to 20 kV. By removing the 35 kV switchboard together with 35/10 kV transformers and by replacing the 10 with a 20 kV switchboard, the new 20 kV switching station can be formed. No extensive documentation and building permits are needed for this solution. The 20 kV switching station will continue to serve its load via existing cables/overhead lines. Laying only a few clean 20 kV cables from the 110/20 kV substation towards the 20 kV switching station is a much cheaper solution than laying many cables directly towards the remote network while bypassing the 20 kV switching

station. This concept is displayed in Fig. 8. Of course, the capacity of the incoming cables must be high enough to cover all the remote load and a thorough load flow analysis must be conducted prior to accepting this solution.

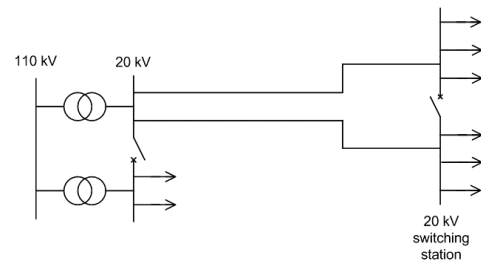

Figure 8 The concept of a remote 20 kV switching station fed by two cables from a 110/20 kV substation

Finally, the 35/10 kV substation can be directly interpolated in the 110 kV transmission network by simply leading the 110 cables inside the station and replacing its 35 and 10 kV switchboards with a 110 kV and 20 kV respectively. This of course must be accompanied with the removal of 35/10 kV transformers and the installation of new 110/20 kV transformers. However, that can only be affordable if the 110 kV network is located in the proximity area, since finding a new parcel and building a completely new 110/20 kV substation is a much costlier solution.

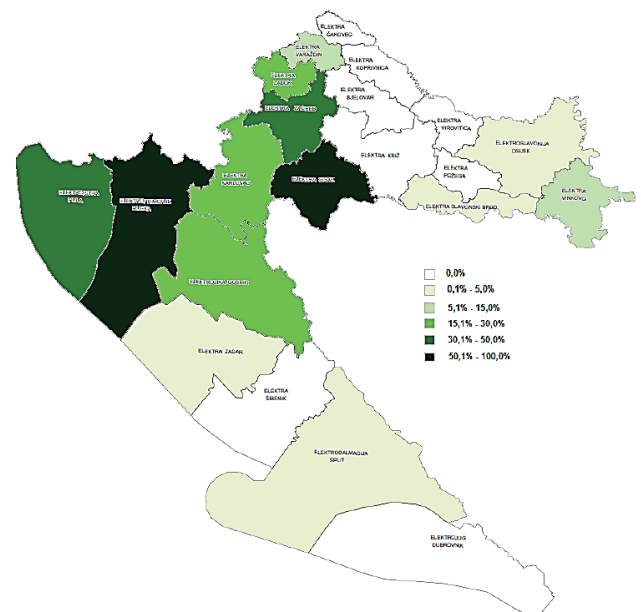

Figure 9 The overall progress of the 10 to 20 kV transition in Croatia

There are many more operational challenges that follow the 10 to 20 kV network transition. However, one challenge is exceptionally important and it covers the contingency analysis ("n-1" state) in the urban areas with an interconnected system configuration (Fig. 5). Since the voltage transition progresses gradually in time, a situation often occurs where one feeding substation is operating on 20 kV secondary voltage (110/20 kV), and the other is on 10 kV secondary voltage (110/10 kV). During the preparation of the second substation and its network for the 20 kV voltage, there is no backup power that can be ensured in the case of an element failure in both 20 and 10 kV feeders. If a 10 kV line experiences a fault, a backup supply cannot be ensured from a 110/20 kV substation, i.e.

on 20 kV level. Since the 10 kV elements are not yet upgraded to withstand the 20 kV voltage, this backup would actually damage them, and so it must be avoided under all costs. Thus, during this process the reliability indices (SAIFI, SAIDI) will drop for local customers, but after its completion the interconnected system configuration will turn back to its regular operation.

As a conclusion, it can be said that the 10 to 20 kV transition has a long way to go before it is implemented in 100% of DSO's network in Croatia. The parts that have successfully adapted over 50% of its network to the single 20 kV medium voltage level are the Primorje-Gorski Kotar County and the Sisak-Moslavina County. Close in pursuit are the Istria County and the City of Zagreb, with over 30% of its network operated on 20 kV. The overall progress of the 10 to 20 kV transition in Croatia is displayed in Fig. 9 [21].

### 8 THE INTEGRATION OF DEMAND RESPONSE AND ELECTRIC VEHICLES IN THE CROATIAN DISTRIBUTION SYSTEM

In the last decade the concept of smart grids has universally become the only concept for a future development of the distribution system. Due to the rapid advancement in communication technology, the smart grid can intelligently integrate activities of all the consumers and producers in real-time while in same time maintaining the safe and efficient supply of electric energy with all the power quality (PQ) parameters in range. Additionally, by using the optical cables or wireless networks for demand response or self-healing, the DSO can actually minimize its network reinforcement costs in the future. However, that will come at a price, since communication technology is vulnerable for external manipulation and even terrorist attacks. The concept of the smart grid, together with its main features is displayed in Fig. 10 [22]. Demand response, energy storage and electric vehicles will be briefly described in this chapter together with their future perspective in the Croatian DSO's grid.

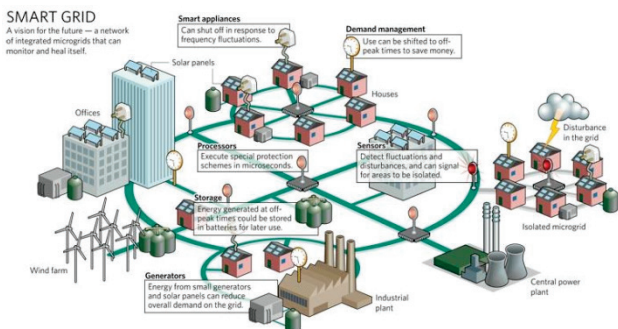

Figure 10 The smart grid concept and its main features

Demand response is actually already used in the Croatian distribution system, but to a rather small extent. It is a part of a so called black tariff system operating in Istria and Dubrovnik-Neretva County. The idea is to lower the electricity price of the consumed energy in kn/kWh for the customers with black tariff, but in return the DSO will have the remote control over their consumption (air conditioners, washing machines, etc.). In that way the DSO can shed these loads just before the overload of the feeding

transformer in the MV/LV substation, thus preventing the activation of protection and preserving the supply of its LV area. However, the peak levelling (termed also peak shaving) can be applied in practice only if the DSO has enough power to shed. In other words, if a 400 kVA transformer is overloaded by 50 kVA and the DSO can shed only 30 kVA, then the overloading is not prevented. Another problem is that even if the DSO has enough power to shed at the moment, the consumption of the area will grow in time, and if the DSO does not acquire more shedding power (customers who sign the black tariff contract), the one at its disposal will become useless in the future.

Maybe the biggest obstacle is that customers in general do not want to relinquish total control of their appliances to utility companies. Even if they do, they can break those contracts at any moment (albeit with an appropriate penalty) and of course cannot be coerced to be a part of demand response indefinitely. This means that even if a DSO has enough shedding power, it can be diminished at any moment. In total, demand response at the moment is not a reliable reason for network deferral, but with the introduction of AMR devices in Croatia, all the technical conditions will be satisfied in order to re-examine this option [23].

The number of electric vehicles (EVs) is also experiencing a steady increase on Croatian roads. There are over 800 EVs with over 140 charging stations scattered throughout Croatia. Also, some Croatian companies even have experience in manufacturing EVs, like the RimacAutomobili Ltd together with their electric car called Concept One. For now, the charging stations offer their services for free since EVs are rather scarce, but this is about to change in the near future.

With the imminent massive introduction of EVs, the distribution networks will surely face difficult problems. The local grids may struggle to balance their power flows if many drivers choose to plug their cars at the same time. This will create additional short-term peaks in daily consumption curves that will require often unnecessary network upgrades. Replacing a 400 kVA transformer with a 630 kVA because of a 450 kVA peak that occurs in only a few minutes is non-optimal, especially if the second lower peak is much under 400 kVA. In order to avoid this scenario, a detailed tariff system must be employed in order to encourage the drivers to plug in during off-peak periods (usually night time) and to use slow charging, since it consumes less power. The difference between non-optimized and optimized charging is presented in Fig. 11 and is a part of the Grid for Vehicles (G4V) project undertaken in EU from 2007 till 2013 [24].

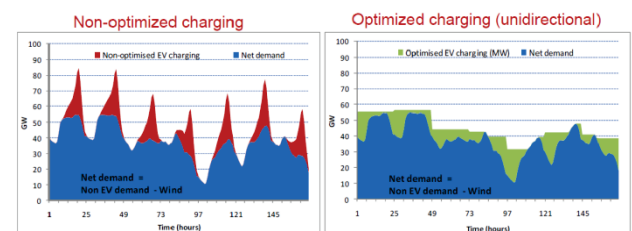

Figure 11 The difference between non-optimized and optimized charging of EVs

The tariff system for EVs is not yet developed in Croatia. However, even with this preventive measure at

DSO's disposal, no one can actually force car owners to charge their vehicles at the required intervals. Furthermore, the additional concept called Vehicle to Grid (V2G), which is based around the premise that the EV can support the grid stability while plugged in, is highly doubtful at least for now. While this ancillary service may prove to be beneficial for the grid, the real question is why would an EV owner degrade its battery pack by draining its battery for the sake of grid stability during peak demand? Since battery is the most expensive component, frequent charging and discharging will definitely reduce its lifetime. This should be adequately compensated by the DSO, but these financial mechanisms have not yet been researched.

Finally, it is interesting to note that, for example, in the UK it was estimated that the National Grid's HV transmission system can currently manage 1 million of electric cars, but a larger penetration would present a serious issue.

## 9 CONCLUSION

This paper has described the problem of active distribution network planning in Croatia from both the theoretical and practical perspective. It can be said that, due to the uncertainty of the future load growth and DG connection, the short-term planning is gaining more relevance than long-term planning, especially since the plans need to be resilient and robust. The technical criteria for the planning of distribution networks in Croatia are about to change, since new Croatian Grid Rules for the Distribution System are underway and will be published in 2018. The scope of the changes yet remains to be seen.

The DG units are by now a standard part of the power system in Croatia and their quota, determined by the Croatian Ministry of Economy, Business and Trade, is almost completely filled. However, if and when this quota is revised and new MWs are allowed to connect to the system, the DSO will have to respond to new emerging challenges. Those challenges address the aggregation of DG units connected in proximity areas. In other words, a large DG unit can sterilize the connection of new producers due to the stretching of the voltage variations in its associated feeder. In that case, any connection of a new production facility would simply break the  $\pm 10\%$  constraints. This can be solved by using the MV/MV booster transformers equipped with OLTC and the Croatian DSO has started to adopt this solution. The MV/MV booster transformers are treated as network reinforcements and are financed by the IPPs as a part of deep connection costs.

Distribution network configurations in Croatia will not change their concept in the future, but the redundancy and reliability issues may be enhanced by allowing the island operation of non-intermittent DG units. However, that needs to be covered in future Croatian Grid Rules for the Distribution System, along with the bandwidth of  $\cos\phi$  operation for voltage support, since for now the DG units must not consume reactive power.

The large number of the input data for distribution system planning will be available during and after the introduction of smart metering. The power system analysis will be more complex and the program tools for performing those tasks need to be adequate in order to have measurable

output results with high quality. The elimination of the 35 kV network and the transition from 10 to 20 kV voltage level will not be over anytime soon, since significant financial resources need to be allocated for this mission. Also, the integration of demand response and electric cars in Croatia will probably go slower than in other countries of the EU. However, the preliminary projects concerning this issue are already underway in Croatia.

As a general conclusion, the planners will face difficulties while determining network expansion and upgrades and for that reason they will have to closely cooperate with DSO's departments for power system operation, protection and maintenance. Hopefully, since Croatia has started its recovery after the recent economic crisis, its state owned power companies like HEP DSO Ltd will have the means to hire even more professionals and engineers, because the journey to the smart grids has just begun.

## Acknowledgment

This work has been financially supported by the University of Rijeka under the Faculty of Maritime Studies projects.

## 10 REFERENCES

- [1] Komen, V. (2007). Model potpore odlučivanju pri planiranju razdjelnih mreža. *Doctoral dissertation*, Faculty of Electrical Engineering and Computing, Zagreb.
- [2] Pečvarac, D. (2000). Podatkovno osnovano određivanje pokazatelja pouzdanosti razdjelne mreže. *Doctoral dissertation*, Faculty of Electrical Engineering and Computing, Zagreb.
- [3] Asakura, T., Genji, T., Yura, T., Hayashi, N., & Fukuyama, Y. (2003). Long-term distribution network expansion planning by network reconfiguration and generation of construction plans. *IEEE Transactions on Power Systems*, 18(3), 1196-1204. <https://doi.org/10.1109/TPWRS.2003.811170>
- [4] Xing, H., Cheng, H., Zhang, Y., & Pingliang, Z. (2016). Active distribution network expansion planning integrating dispersed energy storage systems. *IET Generation, Transmission & Distribution*, 10(3), 638-644. <https://doi.org/10.1049/iet-gtd.2015.0411>
- [5] Wang, D. T., Ochoa, L. F., & Harrison, G. P. (2011). Modified GA and Data Envelopment Analysis for Multistage Distribution Network Expansion Planning Under Uncertainty. *IEEE Transactions on Power Systems*, 26(2), 897-904. <https://doi.org/10.1109/TPWRS.2010.2057457>
- [6] Barukčić, M., Hederić, Ž., & Jović, F. (2008). Adaption of genetic algorithm for more efficient minimization of active power losses in power network. *Tehnički vjesnik*, 15(3), 11-19.
- [7] Stojkov, M., Softić, A., & Atić, M. (2015). Optimization of switching conditions in distribution power subsystem. *Tehnički vjesnik*, 22(5), 1297-1303.
- [8] Skok, M. (2005). Evolucijski algoritam za dinamičko planiranje razdjelnih mreža. *Doctoral dissertation*, Faculty of Electrical Engineering and Computing, Zagreb.
- [9] HEP ODS, 2014. Year report, [http://www.hep.hr/ods/UserDocsImages/publikacije/godisnje\\_izvjesce/godisnje2014.pdf](http://www.hep.hr/ods/UserDocsImages/publikacije/godisnje_izvjesce/godisnje2014.pdf), (19.02.2017.)
- [10] Croatian Grid Rules, [http://narodne-novine.nn.hr/clanci/sluzbeni/2006\\_03\\_36\\_907.html](http://narodne-novine.nn.hr/clanci/sluzbeni/2006_03_36_907.html) (02.05.2017)
- [11] Marijanić, T., Tunjić, A., Alinjak, T., & Habijan, D. (2014). Kriteriji i metodologija planiranja razvoja distribucijske mreže. *HO CIRED*, 4(10) savjetovanje / Trogir/SegetDonji.

- [12] Prenc, R. (2014). Optimalan razmještaj distribuirane proizvodnje u srednjenaponskim elektroenergetskim mrežama. *Doctoral dissertation*, Faculty of Electrical Engineering and Computing, Zagreb.
- [13] Tariff System for the Production of Electrical Energy from Renewable Sources and Cogeneration Plants, <http://www.hrrote.hr/poticajne-cijene>, (13.05.2017)
- [14] Kaluđer, S., Šljivac, D., & Miletić, S. (2012). The optimal placement of distributed generation. *Tehnički vjesnik*, 19(3), 535-541.
- [15] Prenc, R., Škrlec, D., & Komen, V. (2013). Optimal PV System Placement in a Distribution Network on the Basis of Daily Power Consumption and Production Fluctuation. *IEEE EUROCON Conference / Zagreb*, 777-783. <https://doi.org/10.1109/EUROCON.2013.6625071>
- [16] Prenc, R., Škrlec, D., & Komen, V. (2013). Distributed generation allocation based on average daily load and power production curves. *International Journal of Electrical Power & Energy Systems*, 53, 612-622. <https://doi.org/10.1016/j.ijepes.2013.05.033>
- [17] Prenc, R., Škrlec, D., & Živić-Đurović, M. (2015). The implementation of capital budgeting analysis for distributed generation allocation problems. *Electrical Engineering*, 97(3), 225-238. <https://doi.org/10.1007/s00202-015-0330-9>
- [18] Zou, B., Wang, J., & Fushuan, W. (2017). Optimal investment strategies for distributed generation in distribution networks with real option analysis. *IET Generation, Transmission & Distribution*, 11(3), 804-813. <https://doi.org/10.1049/iet-gtd.2016.0541>
- [19] Hung, D. Q. & Mithalanthan, N. (2013). Multiple Distributed Generator Placement in Primary Distribution Networks for Loss Reduction. *Industrial Electronics, IEEE Transactions on*. 60. 1700-1708. <https://doi.org/10.1109/TIE.2011.2112316>
- [20] General Conditions for Network Usage and Electrical Energy Supply, [http://narodne-novine.nn.hr/clanci/sluzbeni/2015\\_08\\_85\\_1666.html](http://narodne-novine.nn.hr/clanci/sluzbeni/2015_08_85_1666.html), (19.05.2017)
- [21] HEP DSO Ltd, 10 years Development Plan [http://www.hep.hr/stariods/UserDocsImages/dokumenti/Planoi\\_razvoja/10g\\_2016\\_2025\\_2016\\_03\\_04\\_a.pdf](http://www.hep.hr/stariods/UserDocsImages/dokumenti/Planoi_razvoja/10g_2016_2025_2016_03_04_a.pdf), (17.01.2017)
- [22] Vijayapriya, T. & Kothari, D. P. (2011). Smart Grid: An Overview. *Smart Grid and Renewable Energy*, 2(4), 305-311. <https://doi.org/10.4236/sgre.2011.24035>
- [23] Klaić, Z., Fekete, K., & Šljivac, D. (2015). Demand side load management in the distribution system with photovoltaic generation. *Tehnički vjesnik*, 22(4), 989-995. <https://doi.org/10.17559/TV-20141205092803>
- [24] G4V – Grid for Vehicles, FP7 project, <http://www.g4v.eu/> (25.05.2017)

**Contact information:**

**Rene PRENC**, PhD, Postdoctorate Researcher  
Faculty of Maritime Studies, University of Rijeka,  
Studentska ulica 2, 51000 Rijeka, Croatia  
[prenc@pfri.hr](mailto:prenc@pfri.hr)

**Ivan STRNAD**, PhD  
Pro Integris Ltd  
Oreškovićevo 8J, 10010 Zagreb, Croatia,  
[ivan.strnad@prointegris.hr](mailto:ivan.strnad@prointegris.hr)

**Vinko TOMAS**, PhD, Full Professor  
Faculty of Maritime Studies, University of Rijeka  
Studentska ulica 2, 51000 Rijeka, Croatia  
[tomas@pfri.hr](mailto:tomas@pfri.hr)