

Techno-economic analysis of the cogeneration process on board ships

Brozičević, Marko; Martinović, Dragan; Kralj, Predrag

Source / Izvornik: **Journal of sustainable development of transport and logistics, 2017, 2, 6 - 15**

Journal article, Published version

Rad u časopisu, Objavljena verzija rada (izdavačev PDF)

<https://doi.org/10.14254/jsdtl.2017.2-1.1>

Permanent link / Trajna poveznica: <https://urn.nsk.hr/urn:nbn:hr:187:537279>

Rights / Prava: [In copyright](#)/[Zaštićeno autorskim pravom.](#)

Download date / Datum preuzimanja: **2024-07-28**



Sveučilište u Rijeci, Pomorski fakultet
University of Rijeka, Faculty of Maritime Studies

Repository / Repozitorij:

[Repository of the University of Rijeka, Faculty of Maritime Studies - FMSRI Repository](#)



Techno-economic analysis of the cogeneration process on board ships

Marko Brozičević *, Dragan Martinović **, Predrag Kralj ***

* University of Rijeka,

Studentska 2, 51000 Rijeka, Croatia

Graduated Student, MR. ing., Faculty of Maritime Studies in Rijeka, Department of Marine Engineering

** University of Rijeka,

Studentska 2, 51000 Rijeka, Croatia

e-mail: dragec@pfri.hr

Associate Professor, PhD, BME, Faculty of Maritime Studies in Rijeka, Department of Marine Engineering

*** University of Rijeka,

Studentska 2, 51000 Rijeka, Croatia

e-mail: pkralj@pfri.hr

Assistant Professor, PhD, BME, Faculty of Maritime Studies in Rijeka, Department of Marine Engineering



Article history:

Received: April, 2017

1st Revision: April, 2017

Accepted: May, 2017

DOI:

[10.14254/jsdtl.2017.2-1.1](https://doi.org/10.14254/jsdtl.2017.2-1.1)

Abstract: Combined heat and power (CHP) is a facility which uses one energy source to produce both electricity and thermal energy at the same time. CHP has an advantage when compared to conventional power plants which produce only electricity or thermal energy because it is much more efficient – it minimizes the usage of its primary energy source, grid losses and greenhouse gas emissions. CHP's big advantage lies in its applicability: it is highly compatible with existing technologies already in use in different power systems across the industry, agriculture, business and residential sector. This paper describes the cogeneration in general, its application, classification and characteristics. It also describes various cogeneration plants on board, their principle and the advantages and disadvantages of individual processes. This paper contains analysis of cogeneration systems and their comparison, especially on board ships. The paper uses results of other authors to analyze on board systems and to suggest optimal solutions for various ship types. The papers aim to become one of the tools for project engineers and operation engineers.

Keywords: cogeneration on ships, trigeneration, analysis, efficiency.

1. Introduction

High energy losses encourage both energy plant's project engineers and operators to find and implement methods of total efficiency coefficient increase. Thermal-electric plant's efficiency coefficient ranges between 35 – 40 %, showing more than half of introduced energy is being lost. The reason for cogeneration plants implementation. Marine propulsion plant in nothing but the energy plant used to convert the thermal energy into the mechanical work, most of which is used for the propulsion of the ship. Efficiency coefficient of such a thermal plant is

Cogeneration (Combined heat and power or CHP) is a procedure that uses primary energy introduced in the process for production of power and thermal energy. Power usually means electric energy used for driving electric motors, or in case of ships for the propulsion, while thermal energy could be used for air and water heating, steam production, in air acclimatization processes and other heating processes.

During transformation of heat in to the power, in accordance with the thermodynamics' basic law some of the energy is rejected in the surroundings, although it could be very useful in the cogeneration process. That leads to the cogeneration process main advantage – better energy efficiency, when compared to the conventional process producing the power or the thermal energy, but not both. Efficiency could be increased up to 70-85 %.

It should, however be pointed out that such values of the efficiency coefficient could be achieved if all of the produced thermal energy is 'consumed'. Such a level of efficiency results with the low CO₂ emissions too.

Cogeneration directive 2004/8/EC from February 11th, 2004 in the article 3 defines cogeneration as a process of contemporary power and thermal energy production. General purpose of the directive is to define methods of efficiency calculation, to create the frame for the affirmation of cogeneration processes and to define the guidelines for its application (Direktiva – Kogeneracija, 2016). Following cogeneration technologies are included: gas turbine combined processes with the exhaust heat usage, counter pressure steam turbines, condensation steam turbines with steam reduction, gas turbines with exhaust heat usage, internal combustion engines, micro turbines, Sterling engines, fuel cells, steam engines, organic Rankine processes and other processes used for contemporary power and thermal energy production (Bošnjaković, 2012; Tireli & Martinović, 2001; Prelec, 2010; Tešnjak, Grgić, & Kuzle, 2011).

As cogeneration efficiency depends on many factors, used technology, type of fuel, size of plants, heat properties being some of them, following classes of cogeneration processes are recognized: industrial cogeneration, heat cogeneration and agricultural cogeneration. Marine plant is an industrial one, but among many processes mentioned before for various reasons only the cogeneration processes with diesel engines, steam or gas turbines as prime energy transformation units are applicable.

The possibility of application of any of the types mentioned before depends on the power and heat demand ratio, which changes constantly during ship's operation. The other advantages have not to be disregarded.

2. Application on board ships

A relatively high temperature of the surrounding, in accordance with the second law of thermodynamics, determines the efficiency of the known heat in to power transformation processes being higher than 50%. The rest of the energy is loss to the environment, or a natural cooling sink. Basically it's a low temperature energy. However, the industrial cogeneration processes gives the possibility of such an energy usage, increase of primary energy usage and, consequently the better usage of fuel's exergy.

From the statistical point of view, considering the tonnage of ships or the power of engines, only the three plants mentioned before are applied. The power is used for ship's propulsion and other auxiliary electric prime movers, while the heat necessitates for the engine room, superstructure and, in some cases, for the liquid cargo. Besides plants with diesel engines, steam and gas turbines, some combinations could also be found.

Efficiency of the cogeneration drops with the increase of the distance between the place of 'production' and the place of 'consumption' of the energy. The price is also increased, not only because

of the production material, but because of the thermal insulation material. In case of ship's plant many of the heat consumers are placed in the engine room. The superstructure isn't far away either. Only the heat consumers related to cargo are more distant.

A simple steam turbine plant producing the electric energy on a ship having the electric motor propulsion is shown on the figure 1. The steam produced in the steam generator expands in the turbine to the pressure respecting to the saturation temperature higher than the heating temperature.

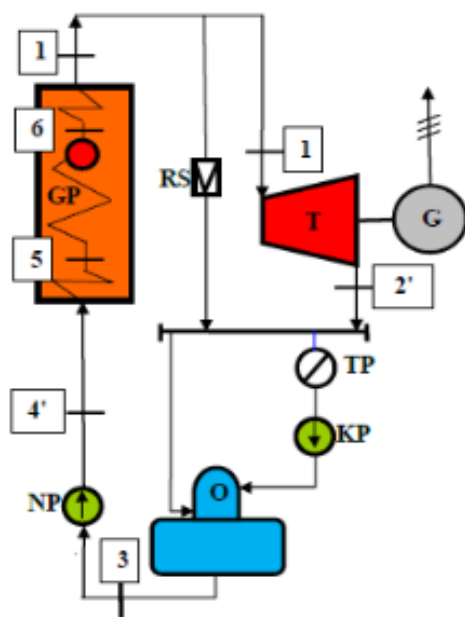

Fig.1. Steam turbine cogeneration plant:

GP – steam generator, T – turbine, G – electricity generator, RS – pressure reduction station, TP – heat consumers, O – deaerator, NP – supply pump, KP – condensate pump

Source: (Prelec, 2010)

Undoubtedly one could not expect the exact electricity and heat demand would always be equal with the production, so the system is equipped with the by-pass using steam pressure reduction valve (RS). Such a steam dump is used in cases when the thermal energy demand over sizes the steam production needed for the production of the electricity. In the opposite scenario the steam surplus could be released to the atmosphere. The operation becomes a more flexible one.

The biggest disadvantage of that process is its inability to balance the electricity and heat according to the actual consumer needs. Hence, the process is usually set to heat demands. This disadvantage is usually resolved by a condensation turbine where the heat demand is regulated with the steam subtraction changes and the electricity demand with the steam flow through the condensation part of the turbine. The system like this is shown on the figure 2.

The turbine has at least two casings, the high pressure and the low pressure one. The steam subtraction happens after the high pressure casing in a manner that there is a constant exit pressure. There is also a by-pass, like in the first process. There are two working regimes: simple condensation process when there is no heat demand and a simple counter pressure process when the heat demand is so high there is no remaining steam for the electricity production, namely the low pressure turbine. In real cases the second one is impossible because about 10% of nominal steam flow through the low pressure turbine have to exist because of the turbine cooling process.

Such a combined production is applicable when constant and reliable electric energy supply is needed. A ship is an example of a plant with needs for reliable electric energy supply, but not a constant one. A setback is also a fact that with the increase of the condensation turbine part the efficiency is reduced.

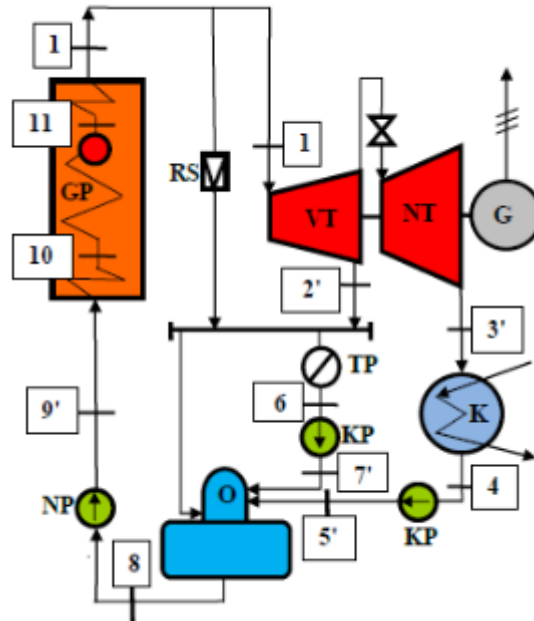

Fig. 2. Steam cogeneration plant with the condensation turbine and steam subtraction:
 GP – steam generator, VT – high pressure casing, NT – low pressure casing (condensation one), G – electricity generator, RS – reduction station, TP – heat consumers, O – deaerator, NP – supply pump, KP – condensate pump, K – condenser,
 Source: (Prelec, 2010)

A very simple way of cogeneration is a combination of a gas and a steam turbine. An exhaust gases steam generator produces the steam for the turbine or for the heat consumers. Since the gas turbine plant has a low efficiency of heat to power transfer and a gas temperatures at the turbine exit are ferly high (about 600°C) there is a possibility of high amount of heat usage in the cogeneration plant. An open cycle like the one shown in the figure 3 would be applied on board ship. Further improvement could be implementation of a composite steam generator through which the plant becomes completely independent and in accordance with the consumer’s demands of either heat or electricity. Although the gas turbine efficiency is very low (25-35%) depending on the type and working parameters, when applied in a cogeneration plants the total efficiency is increased up to 85%. Suggested plants are usually applied on board electric motor propelled ships.

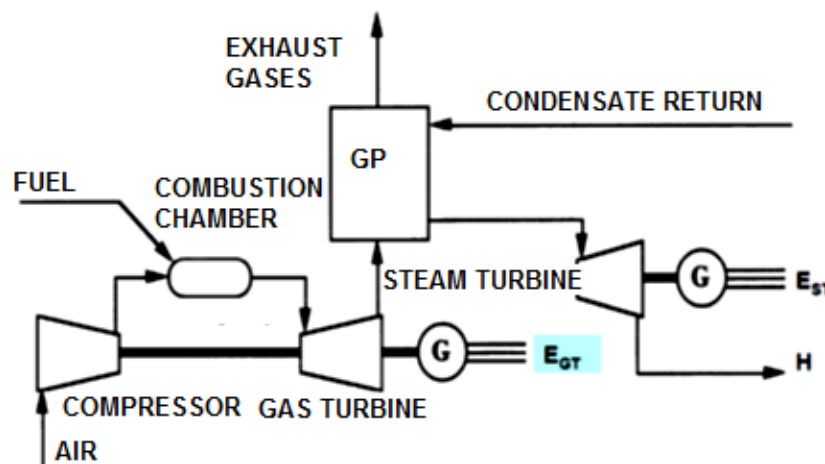

Fig. 3. Combined gas – steam cycle:
 GP – steam generator, G – electricity generator, EGT – electricity produced by the gas turbine, EST – electricity produced by the steam turbine, H – steam for heating
 Source: (Bošnjaković, 2010)

Large ships are mainly diesel engine driven. Furthermore, engines are slow speed or medium speed engines and use heavy fuel oil. Occasionally, fuel has to be switched to diesel oil, and some engines (on liquefied natural gas ships) are dual fuel. Their thermal efficiency is highest, but exhaust temperatures are relatively low. Since its application is being developed through many years there are several well-known and established and few not so accepted methods of exhaust heat recuperation.

Two widely implemented methods of exhaust heat recuperation on board large ships are: firstly, diesel engine exhaust gases waste heat is used for steam production, as has earlier been mentioned in respect of gas turbines, and secondly, diesel engine high temperature cooling water heat is used in fresh water distillation equipment. Obviously, there is also a turbo charger in practically every diesel engine, but it's a part of the engine itself. Not so frequently implemented is usage of exhaust gases turbine to drive the propeller shaft through a gear box or to drive the electric generator. Relatively new is the method of exploiting the scavenge air heat for fuel or other heating purposes. Some of the possibilities are drawn on figure 4.

Approximately 50% of the energy input is lost and, most of it is lost with exhaust gases. If we state that by a turbo charger, separate gas turbine and exhaust gases steam generator everything that is usable is, in fact used, and if scavenge air heat recuperation system is used to heat the fuel tanks, there would be a lot of steam with no purpose. A good way would be to install a steam turbine generator to produce very cheap electricity, instead of diesel generators.

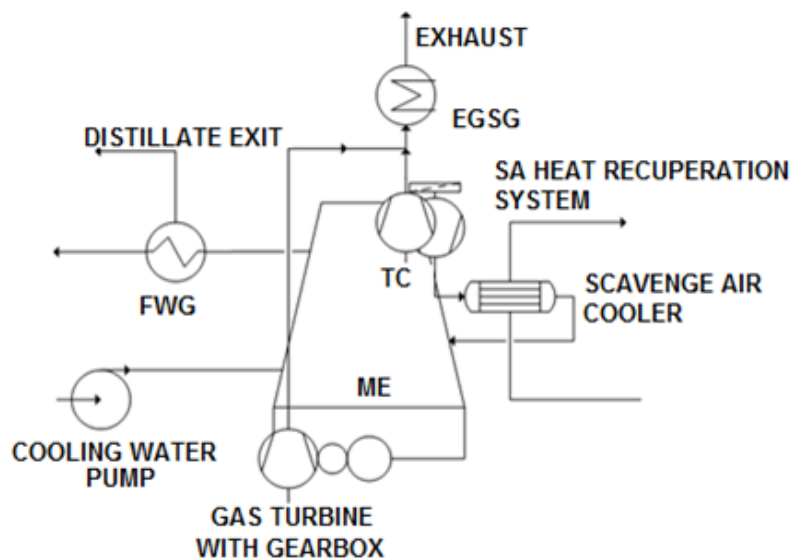

Fig. 4. Main engine waste heat recuperation:

FWG – fresh water generator, ME – main engine, TC – turbo charger, EGSG – exhaust gases steam generator, SA – scavenge air

3. On board cogeneration system's analysis and comparison

Power plants could unequivocally be compared through thermal efficiency coefficient. Since, marine plants produce both power and heat, more criteria shall be considered. Prelec, 2010; Prelec, Z. (1994) suggests following: 1) energy efficiency, 2) used energy value factor, 3) equivalent thermal efficiency, 4) transformation energy equivalent factor, 5) fuel saving factor, 6) energy efficiency.

In case of a stationary plant a change of power over heat ratio during time should be determined. For on board plant that isn't necessary because power is well determined for few operational modes, and if heat needed is higher than available, fuel boiler is used.

The energy efficiency is defined as (Prelec, 1994):

$$\eta_E = \frac{\text{energy used}}{\text{energy consumed}} = \frac{E_M + E_T}{E_G} = \frac{E_M \left(1 + \frac{1}{\psi}\right)}{E_G} \quad (1)$$

Where items represent: η_E – energy efficiency coefficient, E_M – produced power, E_T – produced thermal energy, E_G – consumed energy in the process (by fuel combustion), ψ – power and thermal

energy ratio, i.e. $\psi = \frac{E_M}{E_T}$. Since, this criterion is based on the first law of thermodynamics its disadvantage is that power and thermal energy are equally evaluated.

Used energy value factor represents an improvement because the prices of power, thermal energy and fuel are considered. But if applied on the system given on fig. 4 one can see its flaw – produced fresh water, or its price on the market if it is to be bought isn't considered at all. Fuel saving factor calculates the difference between the fuel consumption in separate power and heat production processes and in a cogeneration process, but has the same disadvantages.

Perhaps the best way is to consider the principle of financial resources accumulation over time. For the calculation not only all of the expenses and earns, but even the time of its appearance is important. Most used are investment return time method and internal rate investment return method.

Common feature of all the cogeneration systems is contemporary power and heat production, depending on the technical possibilities and consumer's demands. The power and heat ratio doesn't changes much during time when stationary plants are in question because it's defined by the structure of the process and its demands, but changes a lot when ship's plant is considered.

Transformation energy equivalent factor $F_{K,E}$ in a cogeneration process is determined by expression (Kogeneracija, 2016):

$$F_{K,E} = \frac{E_G - \frac{E_T}{\eta_{GP}}}{E_M} = \frac{1}{\eta_{t,K}} - \frac{1}{\psi \eta_{GP}} = \frac{1}{\eta_{t,skv}} \quad (2)$$

Ratio considers consumed fuel energy reduction when compared to a consummation of fuel energy used for thermal energy production only.

Several cogeneration systems producing 25 MW of power were compared in source (Kogeneracija, 2016). Following systems have been compared: a) with a fuel boiler having 88% efficiency and using supply water of 110°C and a counter pressure steam turbine having 77% efficiency with steam expanding from 6,4 MPa and 360°C to 1,6 MPa and 210°C; b) with fuel boiler and a condensation turbine with regulated steam subtraction, having the same steam parameters and efficiencies and a vacuum condenser having absolute pressure 0,004 MPa; c) with gas turbine having 31% efficiency using 335 kg/s of exhaust gases and an exhaust gases steam generator with temperature of the gases being 500 – 510°C at the entrance and 150°C at the exit; d) the system as before but with additional burning in a boiler with the maximum amount of fuel is limited with oxygen content in flue gases which rises up to 16%; e) system like in c but with a counter pressure steam turbine like in a; f) system as in e but with additional burning in a boiler; g) system with diesel engine and an exhaust boiler using flue gases having temperature of 380°C, specific fuel consumption being 0,201 kg/kWh, amount of gases is 7,41 kg/kWh and its temperature at the boiler exit being 150°C; h) as in g but with additional burning in a boiler.

Energy efficiency η_E and transformation energy equivalent factor $F_{K,E}$ are drawn on fig. 5 (Kogeneracija, 2016) depending on power and thermal energy ratio ψ .

In a region of small values of ψ (approximately up to 0,1), i.e. where practically only thermal energy is used, the system described in a is the best, its limitation being in point A deriving from turbogenerator's capacity. Such a limitation could be by-passed with a system b, but with a drop in efficiency and increase in $F_{K,E}$. Efficiency drops to 30%, the same value of small power turbines.

System described in c has better energy efficiency η_E and transformation energy equivalent factor $F_{K,E}$ in the entire region of ψ . Its limitation is set in point B (for this example $\psi=0,7$) determined by a maximum steam production in the exhaust boiler. A reduction in the power/heat ratio is accomplished by introduction of additional fuel burning in a boiler as explained in system d. But a limitation also exists in point C, determined with the content of oxygen for the additional combustion.

System e uses high pressure and temperature steam in a counter pressure turbine. The result is increase in efficiency. Its limitation is signed with point D determined with the maximal amount of steam production without additional burning, while the system f that uses additional burning has limitation in point E determined with the maximal amount of fuel that can be burnt without additional air being introduced.

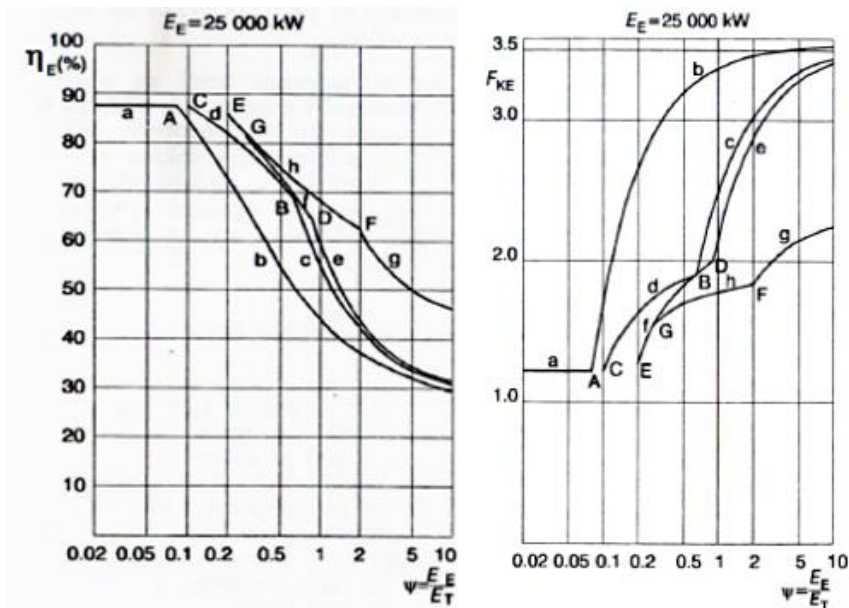

Fig. 5. Energy efficiency η_E and transformation energy equivalent factor F_{KE} of cogeneration systems dependence on power/heat ratio ψ

Source: (Kogeneracija, 2016)

The increase in energy efficiency for higher values of ψ could be accomplished with system g – using diesel engine. The highest value system has in point F, its position being determined by the amount of steam that could be produced using the flue gases energy. With additional burning in the composite boiler higher efficiency values are accomplished – system h.

In the attempt of evaluating the efficiency of some CHP system one could compare him with the systems producing the power and heat separately. The best way would be to calculate fuel consumption in a separate production and in a combined production for several power and heat ratios. In the example the systems producing 25 MW of power with steam production efficiency of 88% and power production efficiency of 40% have been evaluated, through the fuel consumption and the efficiencies.

Fig. 6 shows differences in the efficiencies between the systems producing the power and heat separately and combined. Lower curve shows the efficiency of the separate production while the upper curve shows the combined production in the systems explained earlier. The efficiency dependence is on the power/heat ratio ψ .

The fuel consumption reduction in a combined system when compared with the process of separate production is given with expression (Kogeneracija, 2016):

$$\Delta E_G = E_{G(sep)} - E_{G(comb)} \tag{3}$$

Considering the thermal efficiency of the electricity production and the steam generator’s efficiency, using the expressions for the factor F_{KE} expression (3) results with following [20]:

$$\Delta E_G = E_E \left(\frac{1}{\eta_t} - F_{KE,E} \right) \tag{4}$$

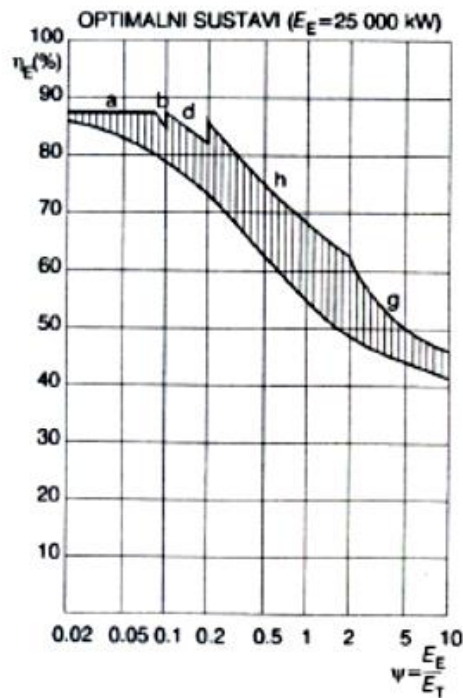

Fig. 6. Efficiency and power/heat ratio dependence diagram

Source: (Kogeneracija, 2016)

From both fig. 5 and 6 one can conclude that for large values of ψ , meaning that power demand highly overpass thermal energy demand – a typical relation for the conventional ships, diesel engine system in any kind of configuration would be the best solution, while for small values of ψ , meaning that power demand is much smaller when compared to heat demand – a typical relation for large crude oil tankers, having large steam consumption for cargo heating, the systems with steam and gas turbines could be better.

4. Conclusions

Almost every field of industry, marine industry included, has the need for different ‘shapes’ of energy and, when fuel cost increase is considered, the constant need for process improvement is understandable.

Cogeneration is well developed approach to increase the efficiency of fuel chemical energy transformation. Although the electric energy production coefficient is reduced, the total energy transformation coefficient is increased.

A trigeneration plants adding a refrigeration process to the power and heat production could give further efficiency increase, resulting with the total efficiency of up to 75%. An implementation of such equipment on board ship should be a matter of additional research.

An on board plant is specific when control mechanisms of ship building are in question. Namely, ships are built according to the classification societies’ regulation. Its role is to accept the tendencies in the energy transformation processes.

Nevertheless, for most of the ships and most of the ship owners diesel engine will still remain the best solution, both in respect of reliability and in fuel consumption and cost saving. Yet, for some types of ships systems combining steam and gas turbines could hold their place on the market.

Appendix A. Supplementary material

Supplementary data associated with this article can be found, in the online version, at <http://jsdtl.sciview.net>

Funding

The authors received no direct funding for this research.

Citation information

Brožičević, M., Martinović, D., & Kralj, P. (2017). Techno-economic analysis of the cogeneration process on board ships. *Journal of Sustainable Development of Transport and Logistics*, 2(1), 6-14. doi:10.14254/jsdtl.2017.2-1.1.

References

- Bošnjaković, F. (2012). *Nauka o toplini*. Raphis.
- Bošnjaković, M. (2010). *Kogeneracija*. Veleučilište u Slavonskom Brodu.
- Brožičević, M. (2016). *Tehnoekonomska analiza procesa kogeneracije* (Doctoral dissertation, University of Rijeka. Faculty of Maritime Studies, Rijeka. Department of Marine Engineering and Ship Power Systems.).
- Cetinić, I., Rengel, T., & Lisjak, D. (2014). *Stručno usavršavanje ovlaštenih arhitekata i ovlaštenih inženjera*. XVII tečaj 14. i 15. studeni 2014.
- Direktiva – Kogeneracija. (2016). Retrived from <http://www.hep.hr/hep/propisi/Direktiva200408Kogeneracija.pdf>. (May 2, 2016).
- Energetske transformacije – Trigeneracija*. (2016). Retrived from http://powerlab.fsb.hr/enerpedia/index.php?title=ENERGETSKE_TRANSFORMACIJE#Trigeneracija (April 28, 2016)
- Grljušić, M. (2012). *Termodinamička analiza i optimizacija rada brodskog pogonskog sporohodnog dizelskog motora s korištenjem otpadne topline*. Doktorska disertacija, Tehnički fakultet u Rijeci.
- HO – CIRED (2016). Retrived from <http://www.ho-cired.hr/referati-umag2010/SO4-22.pdf> (April 28, 2016).
- Hot, K. (2010). Kogeneracijska postrojenja. Tehničko veleučilište u Zagrebu, Studeni.
- Kogeneracija*. (2016). Retrived from <https://hr.wikipedia.org/wiki/Kogeneracija> (January 20, 2016).
- Kogeneracija*. (2016). Retrived from <https://www.scribd.com/doc/233617276/predavanje-4-kogeneracija> (May 12, 2016).
- Kurtela, Ž., (2000). *Osnove brodogradarstva*. Dubrovnik.
- Multimedia Engineering Thermodynamics*. (2016). Retrived from: https://ecourses.ou.edu/cgi-bin/ebook.cgi?doc=&topic=th&chap_sec09.2&page=case_sol (January 20, 2016).
- Parat, Ž. (2005). Brodski motori s unutarnjim izgaranjem. *Fakultet strojarstva i brodogradnje, Zagreb*.
- Prelec, Z. (1994). *Energetics in process industry*. Školska knjiga.
- Prelec, Z. (2010). *Energetska postrojenja*. Tehnički fakultet u Rijeci.
- Rankine cycle* (2016). Retrived from https://hr.wikipedia.org/wiki/Rankineov_ciklus (January 20, 2016).
- Sabathe cycle*. (2016). Retrived from https://commons.wikimedia.org/wiki/File:Sabathe_obieg.png (May 12, 2016).
- Šestan, A. (2016). *Brodski pomoćni strojevi*, Retrived from https://www.fsb.unizg.hr/usb_frontend/files/1382365983-0-bps-skicedijagramprincipijelnesheme.pdf (May 12, 2016).
- Spena, A. (1989). Optimal design of a combined desalination, food freezing and power generation plant. *Heat and Technology (Calore e Tecnologia)*, 7(1), 111-119.
- Tadić, M. (2016). *Kružni procesi*. Retrived from https://www.fsb.unizg.hr/termovel/Kruzni_proces7.pdf (May 12, 2016).

- Tešnjak, S., Grgić, D., & Kuzle, I. (2011). *Kogeneracijska postrojenja*. Fakultet elektrotehnike i računarstva u Zagrebu.
- The institutional repository of Faculty of Mechanical Engineering and Naval Architecture. (2016). Retrieved from http://repositorij.fsb.hr/2470/1/13_09_2013_Proracun_plinsko_turbniskog_postrojenja (April 28, 2016).
- Tireli, E., & Martinović, D. (2001). *Brodске toplinske turbine*. Pomorski fakultet u Rijeci.



© 2016-2017, Journal of Sustainable Development of Transport and Logistics. All rights reserved.

This open access article is distributed under a Creative Commons Attribution (CC-BY) 4.0 license.

You are free to:

Share – copy and redistribute the material in any medium or format Adapt – remix, transform, and build upon the material for any purpose, even commercially.

The licensor cannot revoke these freedoms as long as you follow the license terms.

Under the following terms:

Attribution – You must give appropriate credit, provide a link to the license, and indicate if changes were made.

You may do so in any reasonable manner, but not in any way that suggests the licensor endorses you or your use.

No additional restrictions

You may not apply legal terms or technological measures that legally restrict others from doing anything the license permits.

Journal of Sustainable Development of Transport and Logistics (ISSN: 2520-2979) is published by Scientific Publishing House “CSR”, Poland, EU and Scientific Publishing House “SciView”, Poland, EU.

Publishing with JSDTL ensures:

- Immediate, universal access to your article on publication
- High visibility and discoverability via the JSDTL website
- Rapid publication
- Guaranteed legacy preservation of your article
- Discounts and waivers for authors in developing regions

Submit your manuscript to a JSDTL at <http://jsdtl.sciview.net/> or submit.jsdtl@sciview.net

